

**USER'S GUIDE AND
TECHNICAL REFERENCE**

AC SOURCE

BEHLMAN MODEL BL12000C-1

PART NUMBER: 106-676-401

FOR SERVICE ASSISTANCE

**CONTACT BEHLMAN
CUSTOMER SERVICE DEPARTMENT**

PHONE TOLL FREE 1-800-874-6727

OR WRITE

**BEHLMAN
CUSTOMER SERVICE DEPARTMENT
80 CABOT COURT
HAUPPAUGE, NY 11788**

PHONE: (516) 435-0410

FAX : (516) 951-4341

FOR SALES INFORMATION:

PHONE: (516) 435-0410

USA : (800) 874-6727

FAX : (516) 951-4341

DATE:10/94

REV. —

PACKAGING INSTRUCTIONS

RACK MOUNTED UNITS

1. Box(es) must be double wall with minimum 350 lbs. bursting test.
2. Box(es) must provide for a minimum of 2 to 3 inches of clearance around sides, top and bottom of unit.
3. When packing unit, utilize either a foam-in-place system or high density foam. Clearance provided for above must be completely filled with foam.

FAILURE TO COMPLETELY SECURE UNIT IN BOX WILL ALLOW MOVEMENT DURING SHIPPING, RESULTING IN DAMAGE.

DO NOT USE PEANUTS OR BUBBLE WRAP

4. Secure box(es) to pallet(s). This is necessary to insure proper handling and protection during shipping.
5. Place the following warning label on box(es)
DO NOT STACK
6. Ship unit(s) using a freight cargo carrier; air or ground.

DO NOT USE UPS

CABINET MOUNTED UNITS

Cabinet mounted units require that a special crate be used. The crate should be manufactured of plywood (3/8" or thicker) and reinforced (using 1 x 3 or larger pine) on all edges. The unit must be firmly secured to the crates base. The crate must be shock mounted to avoid damage during shipping.

Detail drawings for Behlman's crates are available upon request.

TABLE OF CONTENTS

BEHLMAN AC SOURCE, MODEL BL12000C-1

SECTION

1	INTRODUCTION
1.1	General Description
1.2	Specifications
2	UNPACKING AND INSTALLATION
2.1	Unpacking
2.2	Installation
3	OPERATION
3.1	Controls and Indicators
3.2	To Operate The Equipment
3.3	Shutdown Procedure
3.4	Single Unit Connection
3.5	Remote Programming
3.6	External Sync
4	MAINTENANCE AND ADJUSTMENT
4.1	Maintenance
4.2	Adjustments
4.3	Phase Adjustment
5	THEORY OF OPERATION
5.1	General
5.2	Input Power
5.3	Control Chassis
5.4	Motherboard
5.5	Output Invertor
5.6	Metering
5.7	Miscellaneous

TABLE OF CONTENTS (cont)
BEHLMAN AC SOURCE, MODEL BL12000C-1

SECTION	DOCUMENT NUMBER
6.	PARTS LIST AND DRAWINGS
	Final Assembly 106-676-401
	Motherboard (Schematic Diagram) 106-948-000
	Phase Control (Schematic Diagram) 106-942-000
	Power Chassis (Assembly) 106-978-0XX
	Power Chassis (Schematic Diagram) 106-956-001
	Control Chassis (Assembly) 106-909-006
	Control Chassis (Schematic Diagram) 106-951-006
	Outline Drawing 106-909-510
APPENDIX	
A	IGBT Driver A-1
B	GPIB IEEE-488 REMOTE INTERFACE B-1

CLAIM FOR DAMAGE IN SHIPMENT

Under the FOB factory terms of sale, ownership and responsibility are transferred to the customer when the equipment leaves the factory. Each Behlman equipment is shipped from the factory in proper operating condition.

Immediately upon receiving equipment, unpack and inspect it for evidence of damage incurred in shipment. File a claim with the freight carrier if the equipment has been damaged in any way or it fails to operate properly. Forward a copy of the damage claim report to Behlman. Include the model number, serial number and date the shipment was received. Behlman will advise the disposition of the equipment and will arrange for necessary repair or replacement.

RETURNING EQUIPMENT TO FACTORY

Do not return equipment to the factory without prior authorization from Behlman.

This equipment, like all precision electronic equipment, is susceptible to shipping damage. It contains heavy magnetic components as well as delicate electronic components.

If equipment is returned without prior authorization, the shipment will be refused, the customer being liable for all shipping, handling and repair costs.

When packing for reshipment, use the original shock absorbent material and shipping container to preclude damage to the equipment.

Insure that the return authorization numbers (RMA) is available on the container.

LIMITED WARRANTY

Behlman Electronics, Inc. warrants, to the original purchaser, for a period of one (1) year from the date of shipment from Behlman, each item to be free from defects in material and workmanship. Behlman's obligation and the Purchaser's sole remedy for any breach or violation of this agreement is limited to adjustments, repair or replacement for parts which have been promptly reported by the Purchaser as having been, in its opinion, defective and so found by Behlman upon inspection. All replacement parts will become the property of Behlman on an exchange basis. This warranty will not apply if such adjustments, repair or parts replacement is required because of accident, neglect, misuse, failure of environmental controls, transportation damage or causes other than normal use.

If during the warranty period a defect should impair the performance of the unit, Behlman agrees, at its option, to repair or replace the unit or its defective components F.O.B. Behlman at 80 Cabot Court, Hauppauge New York 11788 or at another Behlman service facility at Behlman's option. To obtain service under this warranty, the original Purchaser shall notify Behlman at the above address or by Telephone at 516-435-0410 and provide information about the defect or impairment of performance. Behlman will then supply the Purchaser a Return Material Authorization (RMA) number. This number must be attached to the equipment sent back for warranty repair. Equipment must be shipped back to Behlman prepaid. No collect shipments will be accepted.

Behlman shall be excused from supplying warranty service if the units case shall have been opened or if the unit has been subject to unauthorized repair. All service outside the scope of this Warranty shall be paid for by the Purchaser at Behlman's rates in effect at the time of repair. Behlman will not perform any repairs outside of the Warranty without written authorization by the Purchaser. If the repair is a warranty repair, Behlman will ship the unit back to the Purchaser, by a method determined solely by Behlman, prepaid. If the Purchaser requests any other means of transportation it shall be at the Purchaser's expense.

The use of the equipment shall be under the Purchaser's exclusive management and control. The Purchaser will be responsible for assuring the proper installation, use, management and supervision of the equipment. Behlman will not be liable for personal injury or property damage.

The foregoing warranties are in lieu of all other warranties, expressed or implied including without limitation warranties of merchantability and fitness for purpose.

In no event shall Behlman be liable for loss of profits, loss of use, or any other indirect, consequential or incidental damages. Purchaser agrees that Behlman will not be liable for any damages caused by the Purchaser's failure to fulfill any of the Purchaser's responsibilities set forth herein.

SECTION 1
INTRODUCTION

1.1 GENERAL DESCRIPTION

The Behlman AC Source models (table 1) are sophisticated ac power supplies. Each of the models provide independent verification of operating voltage, current, and frequency values thereby lessening the need for external measuring devices. All models provide a single voltage range output.

Any of the models can include all or any combination of the available options if desired (see OPTIONS listed below table 1).

TABLE 1. BEHLMAN MODELS

MODEL	INPUT VOLTAGE (ac)	OUTPUT VOLTAGE (ac)
BL12000C1	120V/208V	0 - 270V, 1 ϕ
BL12000C2	220V/380V	0 - 270V, 1 ϕ
BL12000C3	277V/480V	0 - 270V, 1 ϕ
BL12000C4	200V Δ	0 - 270V, 1 ϕ
BL12000C5	346V/600V	0 - 270V, 1 ϕ
BL12000C6	230V/400V	0 - 270V, 1 ϕ

OPTIONS:

- Add an E to the dash number for extended frequency range.
- Add an I to the dash number for Remote GPIB IEEE-488/RS232 Interface.
- Add a K to the dash number for single phase output.
- Add an L to the dash number for front panel locking controls (VOLTS, FREQ) on voltage and frequency.
- Add an S to the dash number for chassis slides.

1.2 SPECIFICATIONS

INPUT POWER

Voltage: 120/208 Vac, $\pm 10\%$, 3 ϕ

Frequency: 47-440 Hz.

OUTPUT POWER

Voltage: 0-270 Vac, 1 ϕ

Frequency: 45-500 Hz

Maximum Power: 12000 VA

Maximum Current: 50 amperes.

Current Crest
Factor: 3:1

Power Factor: 100% of rated output into any power factor load.

Distortion: 1.5% maximum THD (measured at full load, 100 Vac, 50 Hz).

Load Regulation: $\pm 0.7\%$ from no load to full load.

Line Regulation: $\pm 0.1\%$ for $\pm 10\%$ of line change.

Efficiency: 85-90%

MECHANICAL

Dimensions: 22.06 in. wide, 28.50 in. high, 31.70 in. deep .

Weight: 500 lbs.

Operating
Temperature: 0°C to 55°C (32°F to 131°F).

SECTION 2

UNPACKING AND INSTALLATION

2.1 UNPACKING

After unpacking the AC Source (unit), carefully conduct a thorough inspection of controls, indicators and chassis. If the unit shows signs of damage, do not attempt to operate. File a damage claim with the carrier responsible. Notify Behlman immediately.

2.2 INSTALLATION

- 1) Ensure that the line circuit breaker and all other unit controls are in the OFF position before connecting input power.
- 2) Connect input/output power lines as follows:

CAUTION

Be careful to connect input neutral, if desired to GND stud.

- a) INPUT POWER- Connect 47-440 Hz, power lines to the designated terminals on the INPUT terminal ϕA , ϕB , ϕC on the baseplate of the cabinet.
- b) With a minimum of AWG 6, connect TB1 HI of baseplate to Input HI of the control chassis; TB1 LOW of baseplate to Input LOW of control chassis; TB1 GND of baseplate to Input GND of control chassis..
- c) OUTPUT POWER- Output power lines are connected to the HI and LO terminal strip provided on the baseplate of the cabinet.

NOTE: SEE OUTLINE DRAWING FOR PROPER INSTALLATION.

SECTION 3 OPERATION

WARNING

This equipment involves the use of voltages and currents that can be hazardous. Only qualified personnel should be allowed to operate or service it. The top cover(s) must always be in place during operation.

3.1 CONTROLS AND INDICATORS

Table 1 lists the controls and indicators used on the different models of the AC Source. The table also includes their function. Figure 1 locates these front panel controls and indicators. Also shown are the rear panel REMOTE PRGM connector, two terminal strips, cooling fan, and a GND stud.

3.2 TO OPERATE THE EQUIPMENT

- 1) Ensure that line circuit breaker and OUTPUT switch are set to OFF.
- 2) Connect suitable load across output terminals. (Do not exceed rating of unit.)
- 3) Set line circuit breaker of power chassis to ON (cooling fan noise should become evident).
- 4) Rotate VOLTS control to desired voltage.
- 5) Rotate FREQ control to desired frequency.
- 6) Set OUTPUT switch to ON to energize load.

NOTE

It is permissible to energize a load gradually by setting the OUTPUT switch ON and rotating the VOLTS control from zero to low voltage position up to the voltage desired.

3.3 SHUTDOWN PROCEDURE

- 1) Set OUTPUT switch to OFF.
- 2) Set line circuit breaker to OFF.

TABLE 1. CONTROLS AND INDICATORS

CONTROL/INDICATOR	FUNCTION
Circuit breaker	ON: Connects input power to unit. OFF: Disconnects input power from unit.
CONSTANT CURRENT indicator	Lights to indicate protective circuits are automatically operating to provide rated current and distortionless output during an overload condition.
FREQ control	Used to establish output frequency.
OUTPUT switch	ON: Connects output power to baseplate output terminals. OFF: Disconnects output power from baseplate.
OVERLOAD LATCH indicator	Lights to indicate short circuit protection for overload conditions that disables the output. Overload latch is reset by removing load and recycling power.
OVERTEMP indicator	Lights to indicate over temperature condition and removal of output power. Output power is automatically restored on termination of overtemperature condition.
Digital readout meters	VOLTS: Provides output voltage (RMS) display. AMPS: Provides output current (RMS) display. FREQ: Provides output frequency display.
VOLTS control	Used to establish desired output voltage.
Line drop compensation	Allows for output adjustment due to IR drops in the load lines.

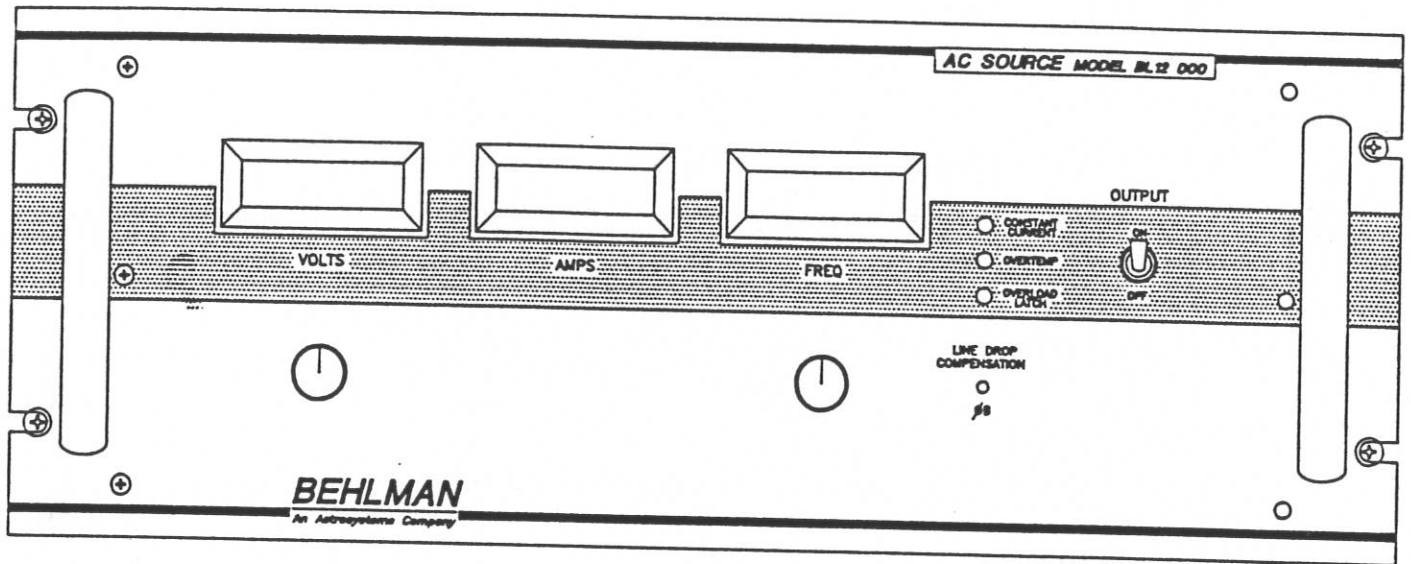

FRONT PANEL

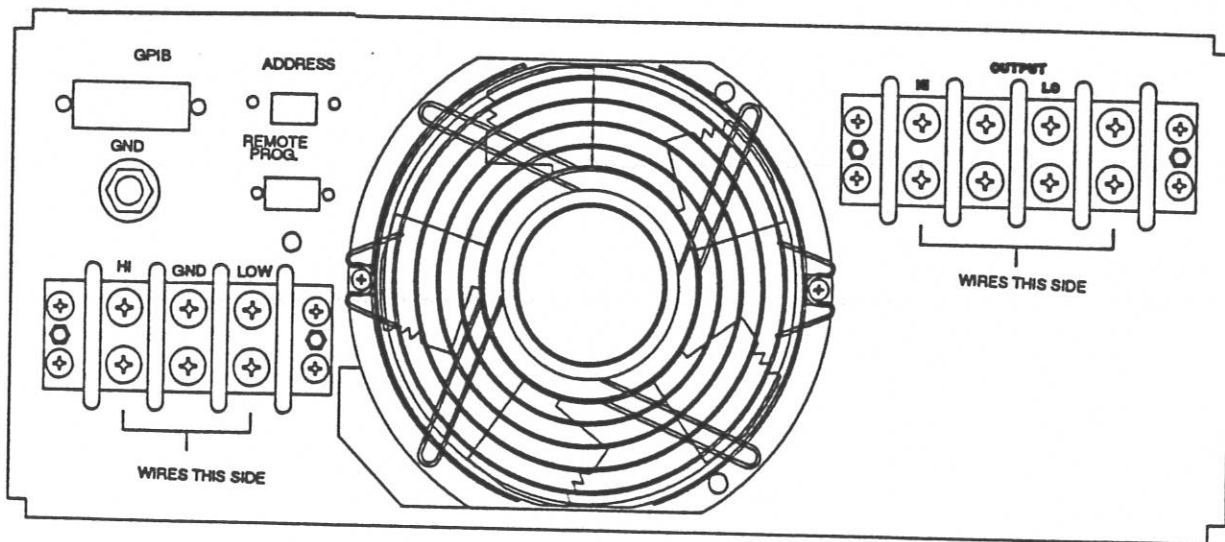

REAR PANEL

Figure 1. AC Source, Front and Rear Panel Views

3.4 REMOTE PROGRAMMING

3.4.1 REMOTE PRGM CONNECTOR

The REMOTE PRGM connector, a nine-pin connector located on the rear panel, is provided to enable the user to program the unit remotely. A mating nine pin male connector is supplied to the user for fabricating the cable required for remotely setting the unit's amplitude, frequency, and on dual range models, the voltage range. It is recommended the user use AWG 20 wire to fabricate the cable.

Table 1 lists the connector pin descriptions. During remote operation, the unit's front panel VOLTS and FREQ controls must be set fully ccw. A isolated 0 to 10 Vdc remote voltage is used to control the unit's output voltage from 0 to full-scale and its output frequency from 45 to 500 Hz.

3.4.2 REMOTE AMPLITUDE AND FREQUENCY CONTROL

Two 0-10 Vdc control voltages from externally isolated voltage sources are used to control the unit's amplitude and frequency via the fabricated remote cable.

TABLE 2. REMOTE PRGM CONNECTOR PIN DESCRIPTIONS

PIN	DESCRIPTION
1	External synch HI
2	External synch LO
3	Amplitude & frequency control (rtn).
4	Amplitude control (hi)
5	Frequency control (hi)
6	Output relay control
7	Output relay control
8	Not used.
9	Not used.

EXTERNAL SYNC

The unit provides for external syncing via its rear panel REMOTE PRGM connector. When an external sync signal is applied to the unit, it reacts to produce an output frequency that is equal to the sync signal regardless of the FREQ control setting. The external sync can be either TTL compatible or an AC signal from 5 to 30 VRMS.

CAUTION

The external sync signal applied to the unit must not be lower than 45 Hz to avoid possible damage to the unit.

ADDENDUM TO OPERATING MANUALS BL SERIES OF AC POWER SOURCES

IMPORTANT NOTE:

The BL series of AC power sources make use of electronic rectification with capacitive filtering. All of these units contain large "banks" of electrolytic capacitors. During the turn on period, these capacitor banks can cause extremely large in-rush current to be drawn. A "soft start" circuit is employed in all units to prevent premature tripping of the unit's input circuit breaker.

The soft start circuit used relies on the time constant for charging the power capacitor banks. When the unit is turned off for any reason, a time period of about one minute is required to allow these banks to discharge. This action "resets" the soft start circuit. Failure to allow sufficient discharge time will result in the breaker tripping at turn on. For more information on the soft start circuit, refer to the theory of operation in this manual.

SECTION 4
MAINTENANCE AND ADJUSTMENTS

WARNING

This equipment involves the use of voltages and currents that can be hazardous. Only qualified personnel should be allowed to operate or service it. The top cover(s) must always be in place during operation.

Before performing any adjustments where access to the inside of the equipment is required, be sure to turn off the unit and allow five minutes for the DC power supply capacitors to discharge.

4.1 MAINTENANCE

WARNING:

FAILURE TO MAINTAIN OR OPERATE THE UNIT PROPERLY WILL VOID THE WARRANTY. AMONG THE ABUSES THAT ARE INCLUDED (BUT NOT LIMITED TO) ARE:

NOT MAINTAINING THE CLEANLINESS OF THE FILTERS (VACUUMING), OPERATING OUTSIDE THE ALLOWABLE ENVIRONMENT, AND PHYSICALLY DAMAGING THE UNIT.

The decision on whether a units warranty is voided will be exclusively reserved for Behlman.

4.2 ADJUSTMENTS

NOTE

All the potentiometers used in the procedures that follow are located on the controller card A1. See the printed wiring assembly in Section 6 for parts location. Always use a non-metallic screwdriver when adjusting potentiometers.

4.2.1 TEST EQUIPMENT REQUIRED

TEST EQUIPMENT	MANUFACTURER/MODEL
Current Clamp	Fluke
	Fluke 80I-600 (or equivalent current transformer)
Digital Voltmeter (DVM)	Fluke 8062A (or equivalent)
Frequency Counter	HP 5314A (or equivalent)
Oscilloscope	Iwatsu SS-5571 (or equivalent)

4.2.2 CONTROLLER CARD POTENTIOMETER ADJUSTMENTS

Since certain potentiometer adjustments affect other associated potentiometer settings, a sequence of adjustments must be followed to ensure the proper setting of each potentiometer within the three groups comprising the unit. The three groups: frequency, voltage, and current, are listed below in the sequence to be performed within each group.

<u>FREQUENCY</u>		<u>VOLTAGE</u>		<u>CURRENT</u>	
<u>POT.</u>	<u>PARA</u>	<u>POT.</u>	<u>PARA</u>	<u>POT.</u>	<u>PARA</u>
R15	4.2.3	R29	4.2.6	R129	4.2.9
R16	4.2.4	R61	4.2.7	F.P.	4.2.10
R19	4.2.5	R58	4.2.8		

4.2.3 LOW FREQUENCY TRIM (45 Hz R15)

- 1) Connect frequency counter to rear panel ϕ A and NEUT terminal strip.
- 2) Turn FREQ control fully ccw.
- 3) Set circuit breaker to ON.
- 4) Set OUTPUT switch to ON
- 5) Set selector switch to ϕ A.
- 6) Adjust VOLTS control until volts meter indicates 10 Vrms minimum.
- 7) Adjust 45 Hz potentiometer R15 until frequency counter indicates 45 Hz.

4.2.4 HIGH END FREQUENCY TRIM (500 Hz R16)

- 1) Turn FREQ control fully cw.
- 2) Adjust 500 Hz potentiometer R16 until frequency counter indicates 500 Hz.

4.2.5 FREQUENCY METER ADJUST (Hz-METER R19)

- 1) Turn FREQ control fully ccw.
- 2) Adjust Hz-METER potentiometer R19 until front panel meter indicates 500 Hz.

4.2.6 FULL SCALE OUTPUT VOLTAGE ADJUST (R29)

- 1) Using DVM set to ac volts, connect it across rear panel HI and LO on output terminal strip.
- 2) Turn VOLTS control fully ccw.
- 3) Set circuit breaker of power chassis to ON.
- 4) Set OUTPUT switch of power chassis to ON.
- 5) Adjust R29 until DVM indicates 120 VMS..

4.2.7 VOLTAGE METER ADJUST (R61)

- 1) Turn VOLTS control fully cw.
- 2) Adjust F.S. potentiometer R61 on ϕ A control card until front panel voltage meter indicates same as DVM.

4.2.8 CURRENT METER ADJUST (I-METER R58)

- 1) Set circuit breaker to OFF.
- 2) Set OUTPUT switch to OFF.
- 3) Turn VOLTS control fully ccw.
- 4) Connect load to rear panel OUTPUT terminals HI and LO.
- 5) Connect current clamp or other current measuring device across load.
- 6) Set circuit breaker to ON.
- 7) Set OUTPUT switch to ON.
- 8) Adjust VOLTS control, making certain current does not exceed 50 amps, to 100 VRMS.
- 9) Adjust I-METER potentiometer R58 on ϕ A board until front panel current meter indication is same as load current noted in step 9.

4.2.9 20 KHz TRIANGLE WAVE TRIM (DIST. TRM R34)

- 1) Turn VOLTS control fully ccw.
- 2) Connect oscilloscope across rear panel ϕ A and NEUT .
- 3) Set oscilloscope gain to 500 mV/div.
- 4) Adjust DIST. TRM potentiometer R34 for smallest waveform peak-to-peak value.

4.2.10 LINE DROP COMPENSATION TRIM

- 1) Connect selected load to rear panel OUTPUT terminals HI and LO.
- 2) Connect DVM at load input so as to compensate for IR losses in the connecting lines.
- 3) Set circuit breaker to ON.
- 4) Set OUTPUT switch to OFF.
- 5) Adjust VOLTS control to desired setting on DVM. Note voltage setting. (Should be the same as the panel meter indication.)
- 6) Set OUTPUT switch to ON.
- 7) Adjust front panel I.R. COMP potentiometer to pre-load voltage setting noted in step 5.

SECTION 5

THEORY OF OPERATION

5.1 GENERAL

5.1.1 The BL10000 and BL20000 series represents low cost, high performance, AC to AC power invertors. These units provide variable output voltage and frequency from 0 to 135 Vac and 45 to 500 Hz respectively. This series may be operated from a 120/208 Vac, 220/380 Vac, 277/480 Vac, 200 Vac (Delta), or 346/600 Vac three phase input line at 50 or 60 Hertz. Other versions include higher single phase outputs and external step-up/down output transformer options.

5.2 INPUT POWER

5.2.1 The BL series models consist of two basic sections, an input power chassis (DC power supply) and an inverter/control chassis. The incoming line voltage is connected to the input chassis where it is applied to a multi-pulse transformer/rectifier system. The output of the rectifier circuit is applied to a large bank of electrolytic capacitors to provide the required filtering. The output of the power chassis is a bipolar DC voltage of +/- 250 Vdc centered around the circuit common. Additional circuitry is incorporated to provide inrush current limiting and overload protection.

5.2.2 Inrush surge limiting is provided by placing large power resistors in series with two of the input phase voltages and the power chassis transformer primary. During power up, these resistors limit the current surge to the filter capacitor bank. Once full voltage is reached, a relay is used to bypass the limiting resistors allowing normal operation.

5.2.3 Over current protection for the DC supply is provided by the multi-pole input circuit breaker. Additional protection is provided by fast acting semi-conductor fuses located in the control chassis.

5.2.4 The output of the power chassis is available at a rear panel mounted terminal block. Connection to the control chassis afforded by supplied jumper cables. Note that the length of these cables is somewhat critical. Do not substitute with long cables.

5.3 CONTROL CHASSIS

5.3.1 The control chassis contains the main power invertors and bias and also the control circuitry. The diagram of Figure 1 depicts the basic functional blocks. Note that in the case of three phase units, only one phase is illustrated as the others are identical. The circuitry is configured so that each of the three "Phase control Cards" plug in to a "Motherboard". The output devices and output filter components are mounted on separate assemblies.

5.3.2 Bias power for the control chassis is derived from the +250 Vdc rail. This voltage is applied to the Motherboard. All other operating voltages are provided by the Motherboard.

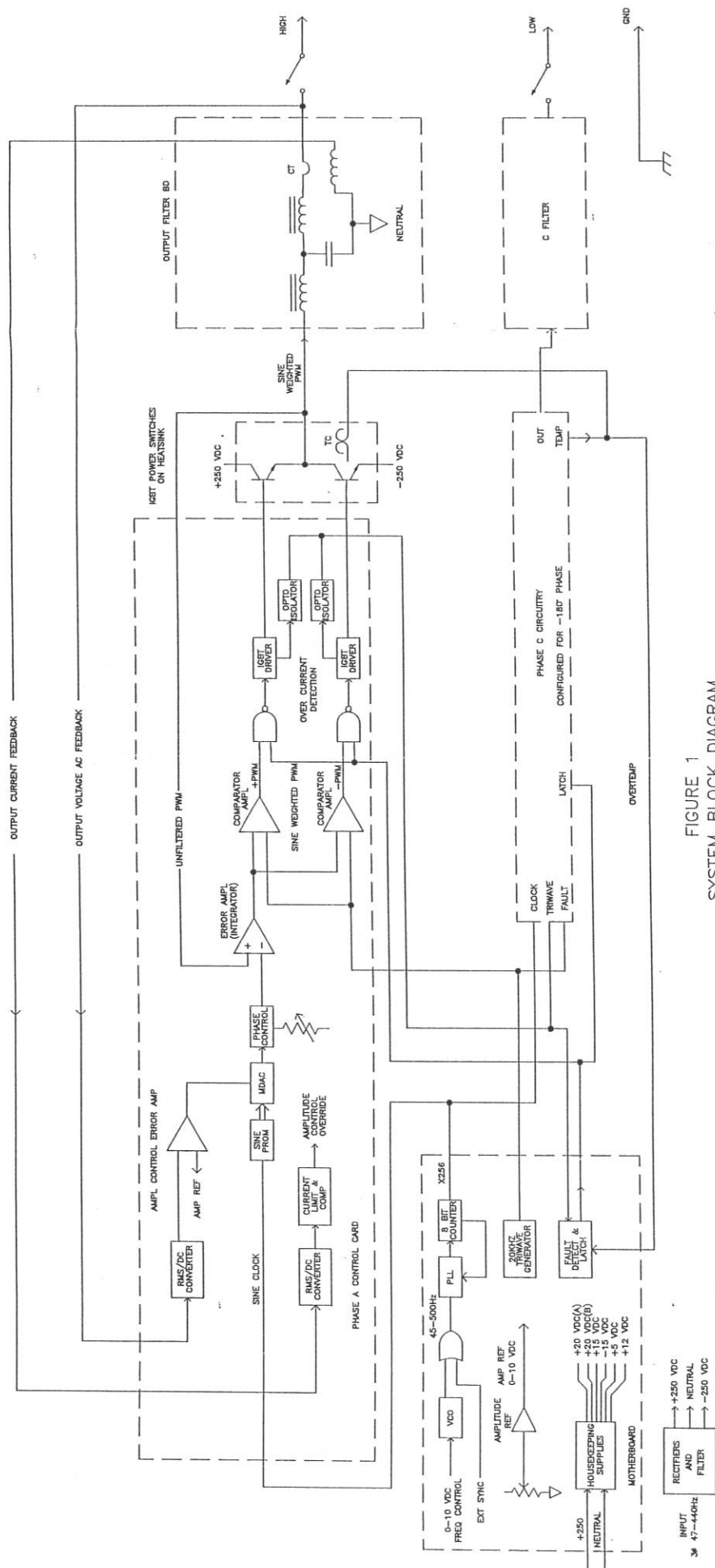

FIGURE 1
SYSTEM BLOCK DIAGRAM
(BRIDGED 0-270 V)

5.4 MOTHERBOARD

5.4.1 The Motherboard uses a flyback type inverter to provide the following low voltage supplies.

- a. +/- 15 Vdc for analog circuits
- b. +5 Vdc for metering circuits
- c. +12 Vdc for fans and relays
- d. isolated supplies for IGBT drivers a quick indication of the supply status is provided by LEDS connected to each supply output.

5.4.2 The variable frequency 45 to 500 Hertz squarewave is generated on the Motherboard. A CMOS phase locked loop (U5), and 8 bit counter (U6) and Voltage Controlled Oscillator (U7) are the basis for the squarewave generator. The front panel frequency control sets a DC voltage which determines the frequency of the VCO generates a squarewave at a frequency between 45 and 500 Hertz. This squarewave is used as a reference signal for the PLL. The frequency of the VCO is multiplied by a factor of 256 by the PLL. The resultant is used as a clock signal for the 8 bit counter.

5.4.3 In order to produce data in the form of a sinewave, a "look-up" table is stored in a PROM on each phase control card. The outputs of the 8 bit counter are tied to the address lines of each PROM. AS the clock runs, the data in the PROMS are clocked into the D/A convertors. This action produces a series of steps at the output of the D/A convertor that approximate a sinewave. Further filtering produces a clean sinewave at the frequency of the VCO. Phase displacement is determined by the PROM data.

5.4.4 The Motherboard also produces a triangle-wave signal that is common to the PWM modulators contained on the phase control cards discussed later.

5.4.5 All inter-connection between circuits and controls are provided via the Motherboard. Four 22 pin card edge connectors are present for the installation of 3 phase control cards and a GPIB interface card. Distribution of all low voltage supplies is via the Motherboard.

5.5 OUTPUT INVERTOR

5.5.1 The three output invertors (3 phase units) are based on a half bridge topology. A 600 volt, 100 amp, IGBT module (1200V for 20K) is connected between the +/-250 Vdc rails. The drive signal to the inverter is a "sineweighted", Pulse Width Modulated (PWM), isolated rectangular pulse train that swings 500 Volts peak-to-peak and has a varying duty cycle based on the modulating signal (sinewave generator). This output is filtered by a low pass network. The result is a sinewave voltage that is an amplified version of the sinewave signal.

5.5.2 Pulse Width Modulation is performed by the individual phase control cards. The tri-wave signal generated by the Motherboard is distributed to each phase control card. Components U7, U12, U13, and U14 form a modulator circuit that provides a dual polarity PWM signal that is applied to opto-coupled driver IC's U17 and U18. These drivers IC's provide boosted, isolated, drive for the upper and lower IGBT of the output inverter. The two inputs to the modulator are the 20 Khz tri-wave and the locally generated sinewave.

5.5.3 The driver IC's provide short circuit protection via an isolated fault output. This circuit detects the VCE voltage of the upper and lower IGBT. If the output of the inverter is shorted the IGBT's collector to emitter voltage will increase and trigger the short circuit detection. The fault detect signal is used to set a latching lock out that turns off the PWM drive signals. The latch logic is comprised of U9, U10, and U12 on the Motherboard. The latch must be reset by cycling power.

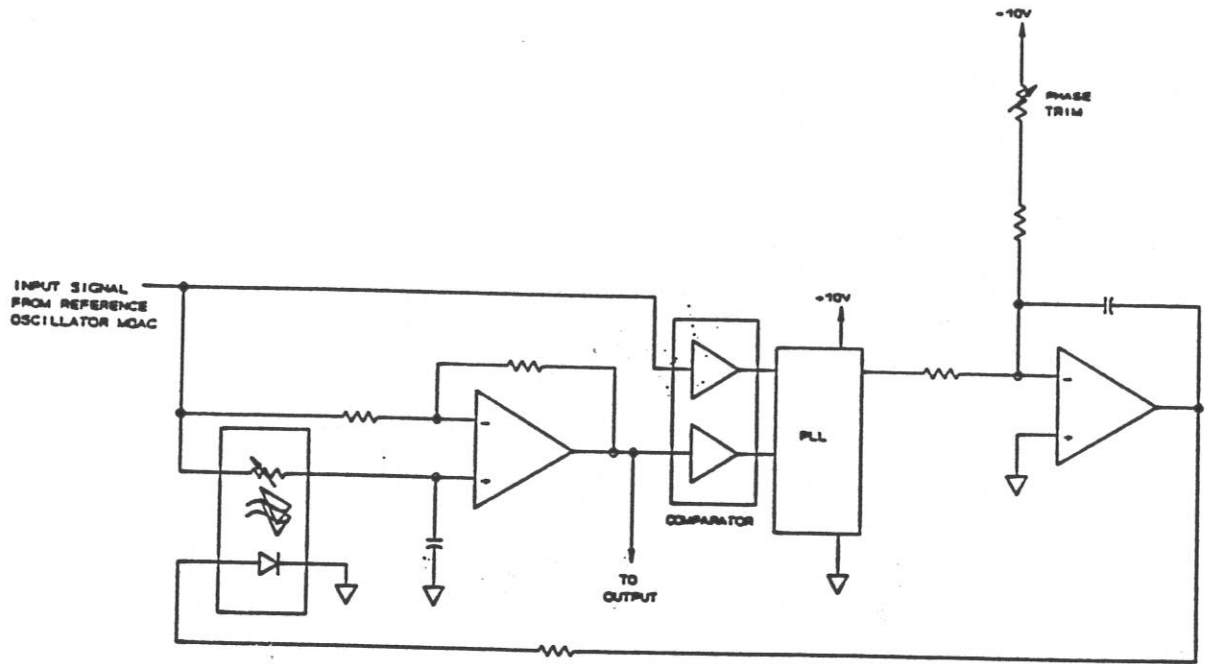

Figure 2. Phase Control Circuit

5.5.4 Individual current limit for each phase is provided by a constant current circuit. This circuit is comprised of U5 and U6 on the phase control card. The transformer and RMS to DC convertor (U5). If the current exceeds a preset limit, the output amplitude control is overridden via the action of U5. This circuit will reduce the output voltage from the phase being overloaded to keep the current constant at about 110% of the rating.

5.5.5 The output amplitude of each phase is also regulated by the control card. A sample of the output voltage is fed to an RMS to DC convertor (U4). The resultant DC voltage is compared to a reference DC voltage set by the front panel voltage control or remote interface. This comparison is performed by U3a and is integrated to provide an error signal to control the amplitude of the sinewave signal fed to the PWM modulator. Compensation for load line (wire) drops is performed by summing in a signal from the current monitor. The more current drawn, the more correction is provided. This compensation is adjustable via the front panel.

5.6 METERING

5.6.1 Metering is provided by DC signals taken from the phase control cards. These signals are derived from the voltage and current monitoring circuits. These signals are attenuated and applied to the front panel DVM's. The frequency display derives it's data from the VCO signal.

5.7 MISCELLANEOUS

5.7.1 Internal heatsink temperature is monitored via an sensor mounted to the extrusion. The sensor is normally open but will close when a safe temperature is exceeded. When this sensor closes the PWM signal is eliminated by setting the same latch used by the short circuit protection.

5.7.2 The optional GPIB board provides an isolated computer interface for remote control of frequency, voltage, and the output relay. The GPIB card will also provide readback of current and voltage to the GPIB.

APPENDIX A

IGBT DRIVER

The insulated gate bipolar transistor (IGBT) driver is a hybrid IC that is used in the overcurrent detector circuit of each BL12000 unit. Two of these drivers are used in each unit to provide signal isolation, overcurrent detection, and low-speed overcurrent cutoff features. Figure 1 shows the internal parts of an IGBT driver and its pin descriptions.

SIGNAL ISOLATION - A photocoupler with a high isolation voltage is used for signal isolation.

OVERCURRENT DETECTION - The IGBT driver can withstand an overcurrent of 10 μ sec duration when short circuited. An extremely fast protection circuit is used here for this reason.

LOW-SPEED OVERCURRENT CUTOFF - A low-speed cutoff circuit slowly turns off the IGBT driver in response to an overcurrent sensing. This feature protects the driver against damage from high voltage spikes generated during normal drive speed cutoffs.

PIN	DESCRIPTION
1	Connected to smoothing capacitor for reverse bias power supply.
2	Power supply (+ 20 Vdc).
3	Drive output.
4	Not connected.
5	Overcurrent detection output.
6	Collector voltage monitoring.
7,8	Not connected.
9	Power supply (0 Vdc).
10-13	Not connected.
14	Drive signal input (-).
15	Drive signal input (+).

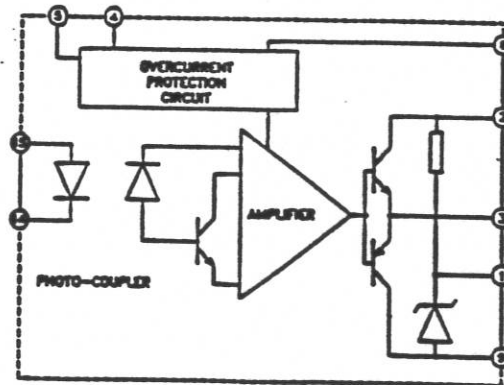

Figure 1. IGBT Driver, Pin Description and Schematic

APPENDIX B

BL SERIES AC POWER SUPPLY IEEE-488 INTERFACE SPECIFICATIONS

1.1 IEEE-488 BUS UTILIZATION

The BL Series Power Supplies incorporates an embedded TMA that is compatible with the electrical and mechanical standards outlined in IEEE-STD-488. The IEEE-488 interface uses a TI LSI device to implement all necessary talker/listener functions. This device is configured under software control to support the following subsets:

- SH1 - Source Handshake
- AH1 - Acceptor Handshake
- T8 - Basic Talker
- L4 - Basic Listener
- DC1 - Device Clear
- RLO - No Remote / Local Function
- SR0 - No Service Request
- PP0 - No Parallel poll response
- DT0 - No Device Trigger
- C0 - Not a controller

1.2 IEEE-488 BUS COMMANDS

1. Single-Line Commands

IFC - Clears GPIB interface

2. Multi-Line Command

DCL - Resets AC Power Supply to the quiescent state if a catastrophic failure is not present. The only way to clear a catastrophic failure is to read the Power Supply's response by using the Status command.

1.3 GPIB COMMUNICATION

The embedded TMA receives ASCII encoded command strings via a GPIB IEEE-488 according to MATE System Control Interface Standard No. 2806763 (IEEE-716 CIIL). Programmed I/O is utilized to transmit and receive command strings after a talker/listener relationship is established. The AC Power Supply supports all OPCODES, NOUNS, and MODIFIERS required by the stimulus module. They are as follows:

OPCODES

FNC, FTH, INX, :CH0, SET, SRX, SRN, CLS, OPN, RST, CNF, IST,
STA

MODIFIERS

FREQ, VOLT, CURR, VLT0, VLT1

NOUN

ACS

1.4 AC POWER SUPPLY SYNTAX

Setup Command:

FNC ACS :CH0 SET VOLT <value>

[SET FREQ <value>]
[SRX VOLT <value>]
[SRN VOLT <value>]
[SRX FREQ <value>]
[SRN FREQ <value>]
[SET VLT(0,1)] <cr> <lf>

Table 1-1

CIIL SOFTWARE COMMANDS

CIIL COMMANDS

EXPLANATION

- All SET, SRX, SRN commands are part of the setup command above.

SET VOLT <value>

Sets output voltage to given value, in volts rms. The following values are permitted:

$0 \leq \text{value} \leq 34$, or 135, or 270, dependent on range selected and type of unit.

If set volt (value) not received, then use SRN VOLT (value), or SRX VOLT (value). If none of these 3 are sent then generate error message.

SET FREQ <value>

Optional. Sets frequency of output voltage to given value, in Hz. The following values are permitted:

$45 \leq \text{value} \leq 500$.

Default is 60 Hz only if SET FREQ, SRN FREQ, or SRX FREQ are not received. Otherwise the values shall be used in the order stated.

SRX VOLT <value>

Optional. Sets maximum limit for SET VOLT command. If SET VOLT value is greater than SRX VOLT value in a command string, an error message is generated and the setup command ignored. The following values are permitted:

$0 < \text{value} \leq 34$, or 135, or 270, dependent on range selected and type of unit.

If a value for SRX VOLT is not specified, the required maximum value for SET VOLT default to 34, or 135, or 270, dependant on range selected and type of unit.

Table 1-1
CIIL SOFTWARE COMMANDS (cont)

<u>CIIL COMMANDS</u>	<u>EXPLANATION</u>
SRN VOLT <value>	<p>Optional. Sets minimum value limit for SET VOLT command. If SET VOLT value is less than SRN VOLT value in a command string, an error message is generated and a setup command ignored. The following values are permitted:</p> <p>$0 \leq \text{value} < 34, \text{ or } 135, \text{ or } 270$, dependent on range selected and type of unit.</p> <p>The SET VOLT default is 0 for the minimum value if a value is not specified for SRN VOLT.</p>
SRX FREQ <value>	<p>Optional. Sets maximum limit for SET FREQ command. If the SET FREQ value in a command string is greater than the maximum limit, an error message is generated and the setup command ignored. Legal values are:</p> <p>$45 < \text{value} \leq 500$.</p> <p>If a value for SRX FREQ is not specified, SRX FREQ defaults to 500.</p>
SRN FREQ <value>	<p>Optional. Assigns minimum value to SET FREQ command. If the SET FREQ value in a command string is less than the minimum limit, an error message is generated and the setup command ignored. Legal values are:</p> <p>$45 \leq \text{value} < 500$.</p> <p>If a value for SRN FREQ is not specified, SRN FREQ defaults to 45.</p>
SET VLT0	Set LO voltage range.
SET VLT1	Set HI voltage range.

Delay is necessary after issuing setup command, due to output voltage slew rate of 100v per 250 ms.

On dual range Power Supplies, this command selects the LO or HI voltage range. Dual Ranges are 0-34 volts 0-135 volts and 0-135/0-270 volt. If this command is omitted from the setup string the unit will default to the lowest available range. On single range units this command will be ignored.

NOTE

1. The setup command specifies the voltage and frequency of the AC power Supply output. The AC Power Supply responds only to the last setup command entry. Its memory does not retain previously entered setup commands.

2. During IEEE operation, the unit's front panel VOLTS and FREQ controls must be fully CCW. If the controls are not set fully CCW, then the output voltage and frequency will be a sum of the programmed value and the value set with the front controls.

Front Panel OUTPUT switch must be set to OFF position.

Front Panel RANGE switch (on dual range units) must be set to LO.

Table 1-1
CILL SOFTWARE COMMANDS (cont)

<u>CILL COMMANDS</u>	<u>EXPLANATION</u>
FTH VOLT <cr> <lf>	The AC supply responds to this command by transmitting the RMS voltage (in volts resolute to 0.1V) measured at its output, in decimal format as follows: <sp> <digit> <digit> <digit> <dp> <digit> <cr> <lf>
FTH CURR <cr> <lf>	The AC Supply responds by transmitting the current (in amps resolute to 0.1A) measured at its output, in decimal format, as follows: <sp> <digit> <digit> <dp> <digit> <cr> <lf>
FTH FREQ <cr> <lf>	The AC Supply response by transmitting the frequency (in hertz) measured at its output, in decimal format, as follows: <sp> <digit> <digit> <digit> <cr> <lf>
CLS :CH0 <cr> <lf>	Closes output relay contacts. Connects AC Power Supply outputs to output terminal block. The setup command specifies the voltage and frequency. The setup command must be entered before the CLS :CH0 command.
OPN :CH0 <cr> <lf>	Opens output relay contacts. Disconnects output of AC Power Supply from output connector. AC Power Supply retains voltage and frequency assigned by setup command.
RST ACS :CH0	Resets AC Power Supply to quiescent. The output relay opens and error messages are erased. Catastrophic error messages are cleared by reading the Power Supply's response, by use of the Status command.
CNF <cr> <lf>	Instructs AC Power Supply to perform internal confidence test. STA command transmits the message. The AC Power Supply responds with one of the following: <u>Pass</u> <sp> <cr> <lf> <u>Fail</u> F07ACS0(DEV): CONFIDENCE TEST FAILURE <cr> <lf>

Table 1-1
CILL SOFTWARE COMMANDS (cont)

IST <cr> <lf>

Instructs AC Power Supply to perform internal self test. The STA command transmits the message. The AC Power Supply responds with one of the following:

Pass

<sp> <cr> <lf>

Fail

F07ACS0(DEV): BIT TEST FAILURE

-PROM CHECKSUM FAULT

-RAM FAULT

-AC SUPPLY HARD FAULT

<cr> <lf>

CILL COMMANDS

EXPLANATION

STA <cr> <lf>

Status. Prepares AC Power Supply for a response transmission. Clears error condition if one exists. The following response messages and conditions exclude confidence and internal self <sp> <cr> <lf>

Device error messages

F07ACS0(DEV):BIT TEST FAILURE

<description consisting of up to 60 characters> < cr> <lf>

TMA error messages All begin with:

F07ACS0 (MOD):

This message is followed by one explanatory message from the following text:

ILLEGAL NOUN

AC Power Supply does not recognize illegal noun.

ILLEGAL NOUN MODIFIER

AC Power Supply does not recognize illegal noun modifier.

ILLEGAL OPCODE

AC Power Supply does not recognize illegal opcode.

ILLEGAL VALUE

Entered value lies outside upper and lower limits.

NO SETUP

Close command received but setup not programmed.

Example: F07ACS00(MOD): NO SETUP <cr> <lf>

1.5 CATASTROPHIC ERRORS

A catastrophic failure is generated each time the AC Power Supply experiences a hardware failure. Errors are cleared whenever the AC Power Supply transmits a response, except in the case of a short circuit fault which may only be cleared by cycling power to the AC Supply.

Catastrophic Error Messages

All begin with:

F00ACS0(DEV):

This message is followed by one explanatory message from the following text:

OVERTEMP FAULT <cr> <lf>

The heatsink temperature has exceeded its upper limit. The OVERTEMP LED on the front panel will light.

CURRENT LIMIT FAULT <cr> <lf>

SHORT CIRCUIT FAULT: AC SUPPLY <cr> <lf>

An output loading fault has occurred causing the supply to exceed 500% rated current output. The supply automatically shuts down and opens its output relay. The OVERLOAD LATCH LED on the front panel will light.

1.6 ADDRESS SELECTION

The GPIB Address for the BL Series Power Supplies is configured via the dipswitch located on the rear panel. The dipswitch represents the address in binary format. Valid GPIB Address settings are from 0 to 30. Switch 1 is the LSB, switch 5 is the MSB. Each individual switch bit is set ('1') when in the 'OFF' position and reset ('0') when in the 'ON' position.

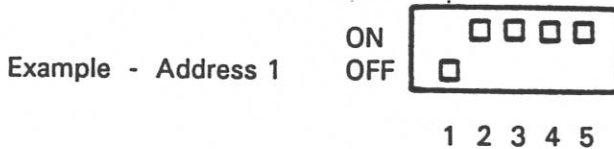

<u>Dipswitch Element</u>	<u>Equivalent Binary Value</u>
1	1
2	2
3	4
4	8
5	16

1.7 THREE PHASE COMMUNICATION

The GPIB Interface of the BL Series has additional Fetch commands which allows the user to Fetch voltage and current from each phase. If no phase is specified during a Fetch for current or voltage, then the response is an average of the three phases.

FETCH DATA COMMANDS FOR THREE PHASE UNITS

FTH VOLT <1, 2, or 3> <cr> <lf>	The AC Supply response to this command by transmitting the RMS voltage (in volts) for the individual phase specified, measured at its output.
FTH VOLT <cr> <lf>	The AC Supply responds by transmitting the average RMS voltage for the 3 phases.
FTH CURR <1, 2 or 3> <cr> <lf>	The AC Supply responds by transmitting the average current (in amps) for the individual phase specified, measured at its output.
FTH CURR <cr> <lf>	The AC Supply responds by transmitting the average current for the 3 phases.

All other commands for Fetch remain the same as the BL1350, described on page B-4 of this appendix.

The setup commands for the three phase units remain the same for the BL1350. The operation of the BL Units prohibit adjusting voltages for phases individually, therefore phase cannot be specified during the "SET VOLT" command.

GPIB PROGRAMMING EXAMPLES FOR BL1350

Examples of actual command strings transmissions and typical responses are outlined below.

All commands must be in upper case ASCII, lower case characters are ignored. All commands transmitted to the BL1350 must terminate with a carriage return <cr> and a line feed <lf>, as will all responses received from the BL1350 .

IMPORTANT NOTE: The EOI line of the GPIB controls **MUST** be asserted when transmitting the line feed character, otherwise the BL Source will not recognize command reception and command processing will not occur.

1. **EXAMPLE:** Setup a single range BL Source to output 120 V @60 Hz, and close the output relay.

Transmit setup command:

FNC ACS :CH0 SET VOLT 120 SET FREQ 60<cr><lf>

Transmit status command to request status response:

STA <cr><lf>

Talk address the BL Source to enable response:

<space><cr><lf> : Positive response indicating status is OK.

F07ACS00 (MOD) ILLEGAL VALUE <cr><lf>: Negative response indicating error condition.

(Typically a negative response would only occur if an error existed in the entry or reception of the command string, or the values entered were out of range of the BL Source).

Transmit output relay close command:

CLS :CH0 < cr><lf>

Transmit status command to request status response:

STA <cr><lf>

Talk address the BL Source to enable response:

<space><cr><lf> : Positive response indicating status is OK.

F07ACS00 (MOD) NO SETUP <cr><lf> : Negative response indicating error condition.

(Negative response would only occur if invalid or no setup string had been transmitted prior to close command).

2. **EXAMPLE:** Setup a dual range BL Source to output 30 V on low range @400 Hz.

Transmit setup command:

FNC ACS :CH0 SET VOLT 30 SET FREQ 400 SET VLT0 <cr><lf>

Transmit status command to request status response:

STA <cr><lf>

Talk address the BL Source to enable response:

<space>< cr><lf> : Positive response indicating status is OK.

3. EXAMPLE: Setup a dual range BL Source to output 115 V on high range @50 Hz, and read back what the actual voltage, current, and frequency being output is set at.

Transmit setup command:

FNC ACS :CH0 SET VOLT 115 SET FREQ 50 SET VLT1 <cr> <lf>

Transmit status command to request status response:

STA <cr> <lf>

Talk address the BL Source to enable response:

<space> <cr> <lf> : Positive response indicating status is OK.

Transmit output relay close command:

CLS :CH0 < cr> <lf>

Transmit status command to request status response:

STA <cr> <lf>

Talk address the BL Source to enable response:

<space> <cr> <lf> : Positive response indicating status is OK.

Transmit fetch volt command:

FTH VOLT <cr> <lf>

Talk address the BL Source to enable response:

115.0 <cr> <lf>

Transmit fetch current command:

FTH CURR <cr> <lf>

Talk address the BL Source to enable response:

5.2 <cr> <lf>

Transmit fetch frequency command:

FTH FREQ < cr> <lf>

Talk address the BL Source to enable response:

50.0 <cr> <lf>

GPIB PROGRAMMING EXAMPLE FOR THREE PHASE UNIT

1. **EXAMPLE:** Setup single range BL Units to output 120 V @ 60 Hz and read back actual voltage and current from phase 2 and the average voltage. Assume for this example a load is connected drawing 1.5 amps RMS from phases 1 and 2, 0 amps from phase 3.

Transmit setup command:

FNC ACS: CH0 SET VOLT 120 SET FREQ 60 <cr> <lf>

Transmit status command to request status response:

STA <cr> <lf>

Talk address the BL source to enable response:

<space> <cr> <lf>: Positive response indicating status is OK.

Transmit output relay close command:

CLS :CH0 <cr> <lf>

Transmit status command to request status response:

STA <cr> <lf>

Talk address the BL source to enable response:

<space> <cr> <lf> Positive response indicating status is OK.

Transmit fetch volt command for phase 2:

FTH VOLT2 <cr> <lf>

Talk address the BL source to enable response:

120.0 <cr> <lf>

Transmit fetch volt command for average of 3 phases:

FTH VOLT <cr> <lf>

Talk address the BL source to enable response:

120.0 <cr> <lf>

Transmit fetch current command for phase 2:

FTH CURR2 <cr> <lf>

Talk address the BL source to enable response:

1.5 <cr> <lf>

Transmit FTH current command for average of 3 phases:

FTH CURR <cr> <lf>

Talk address the BL source to enable response:

1.0 <cr> <lf> Average of 3 phases.

SECTION 6

PARTS LIST AND DRAWINGS

PROPRIETARY
 THE PROPRIETARY INFORMATION CONTAINED IN THIS DOCUMENT MUST NOT BE DISCLOSED TO OTHERS FOR ANY PURPOSE, NOR USED FOR MANUFACTURING PURPOSES WITHOUT PERMISSION OF BEHLMAN ELECTRONICS INC. THE ACCEPTANCE OF THIS DOCUMENT WILL BE CONSTRUED AS AN ACCEPTANCE OF THE FOREGOING CONDITION.
 BEHLMAN ELECTRONICS INC.
 HALPPAUGE, NEW YORK

REVISION HISTORY						
ZONE	LTR	DESCRIPTION	DATE	APPROVED	DRL #	INT.
-	-	INITIAL RELEASE				
A		ADDED (2) 5 OHMS RESISTOR TO K1				
B		REVISED AND REDRAWN PER ECO 13-016	1/9/13	RKL		

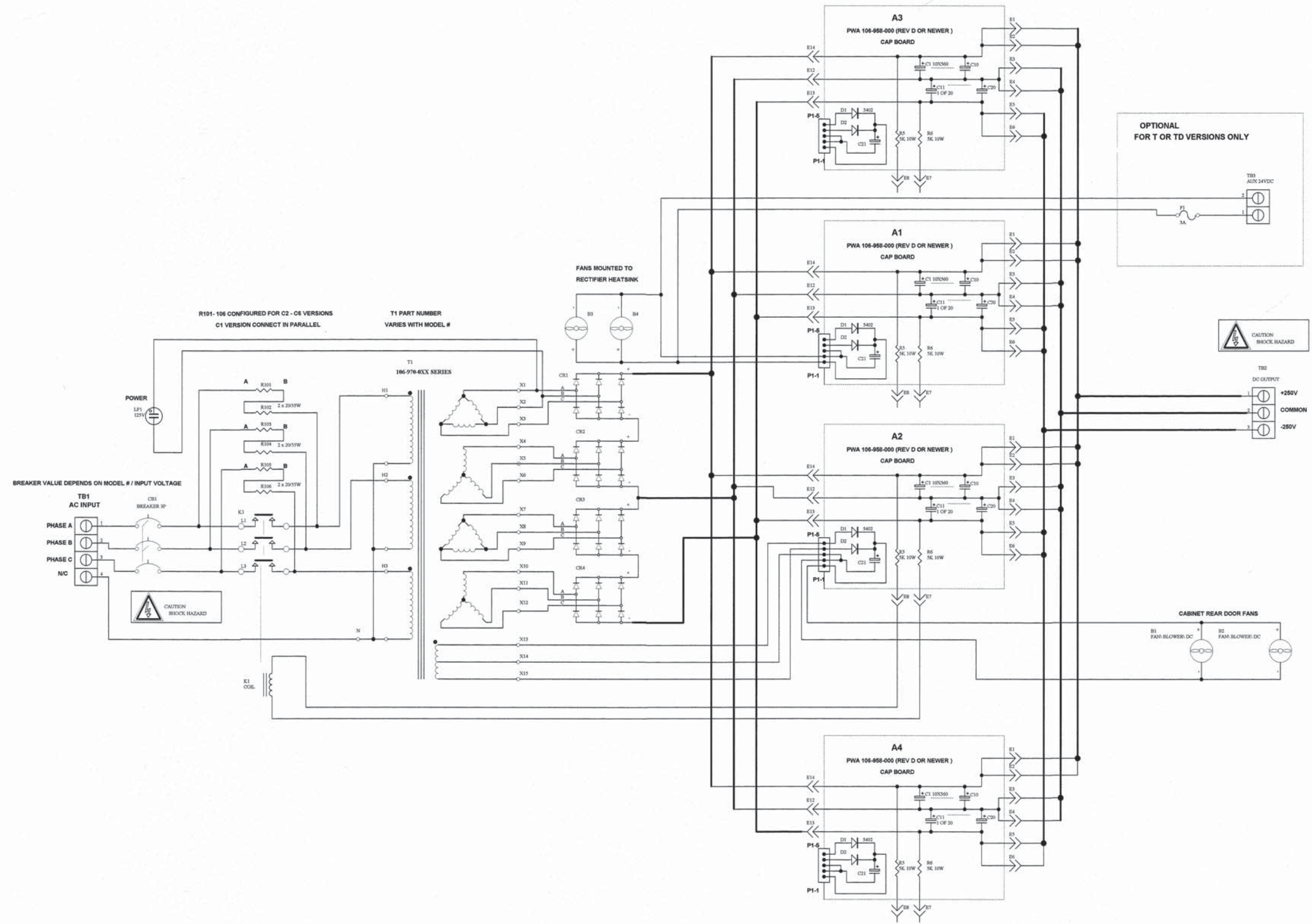

CONTROLLED DOCUMENT

UNLESS OTHERWISE SPECIFIED DIMENSIONS ARE IN INCHES TOLERANCES: 3 PLACE DEC: +.005 2 PLACE DEC: +.02 ANGLES: ±1°			THIS DRAWING SHALL ONLY BE CHANGED BY USE OF CAD		BEHLMAN	
DO NOT SCALE THIS DRAWING			DRAWN: S. BOEGLE DATE: 4/24/2012		NOMENCLATURE: SCHEMATIC DIAGRAM	
MATERIAL:			CHECKED: [Signature] DATE: 1/31/13		BL 12K, 15K, 20K 3PHASE INPUT	
106-977-002	106-976-0XX	HPBL 12K, 15K, 20K	DATE: 1/22/13	SIZE: D	CODE IDENT NO. PART NO. 53636 106-956-001	REV B
NEXT ASSY.	USED ON	DESCRIPTION	DATE	SCALE	CAD FILE	SHEET 1 OF
APPLICATION						

106-956-001

REV STATUS OF SHT	ZONE	LTR	REVISIONS		DATE	APPROVED
			DESCRIPTION			
SHT REV			ORIGINAL	RELEASE	93-7-28	RA

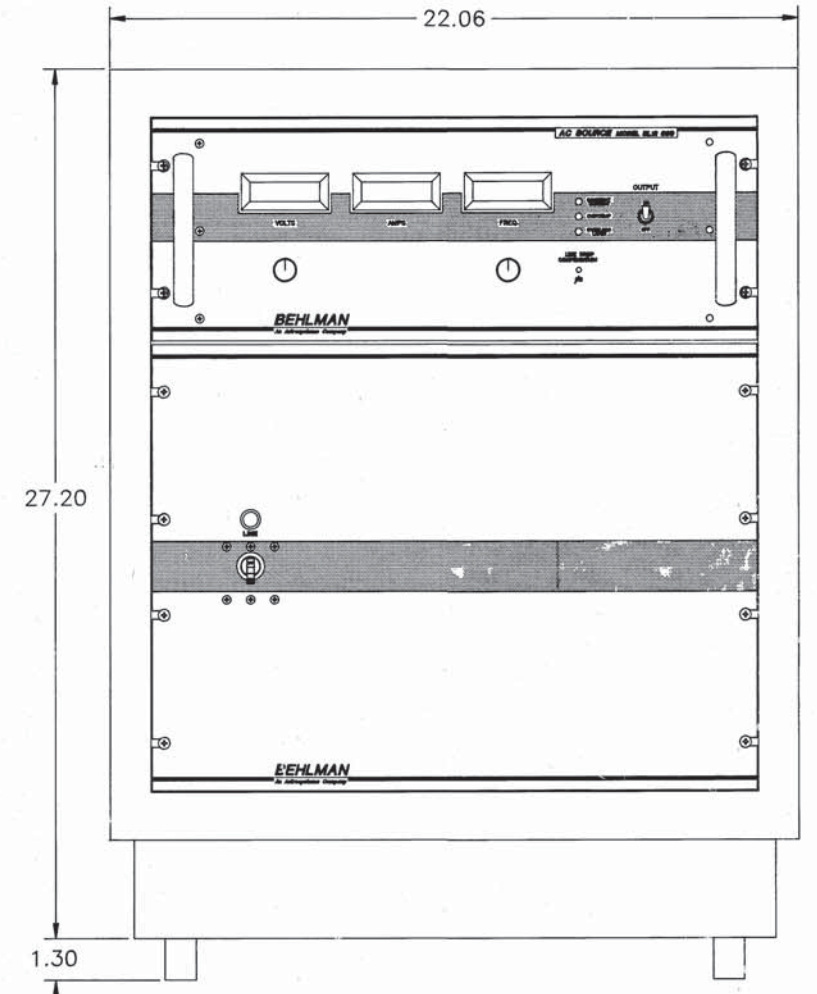
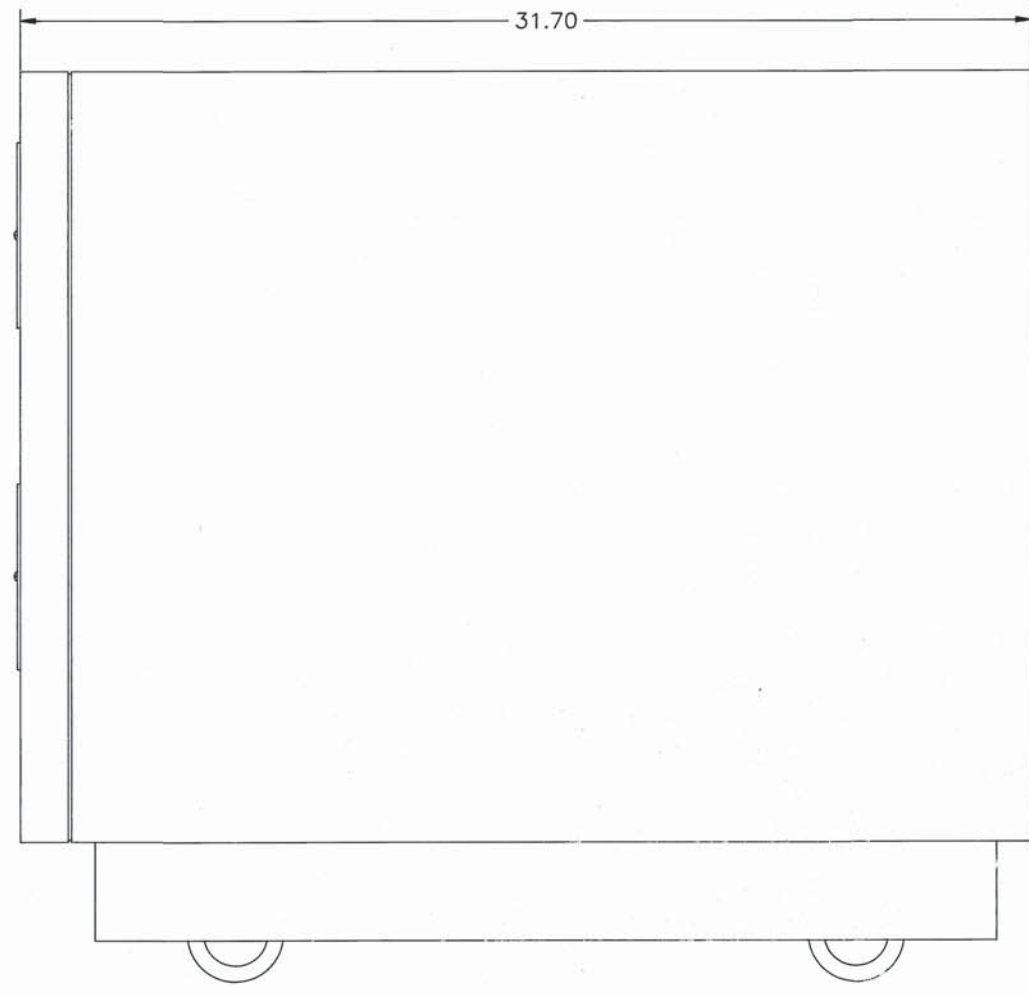
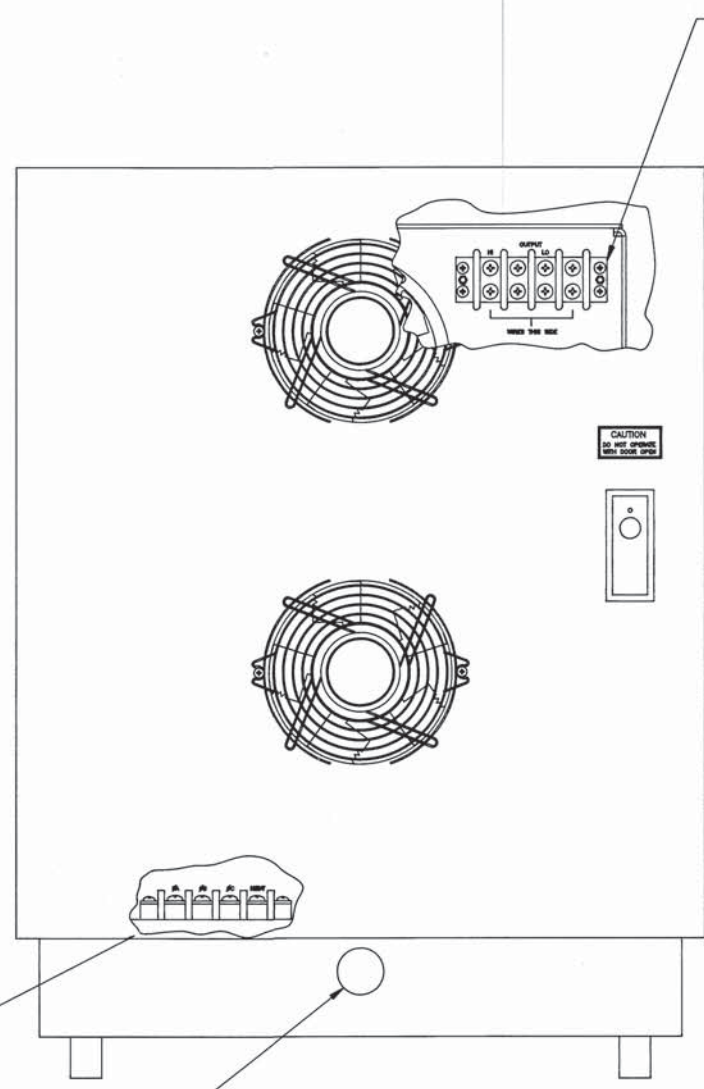

SEE DETAIL B
CUSTOMER INPUT/OUTPUT WIRE ACCESS HOLE

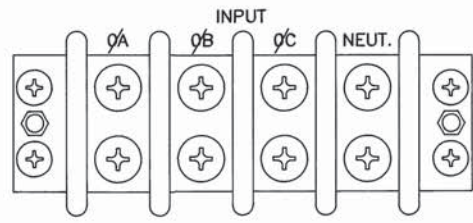

DETAIL B
SCALE: 1:1

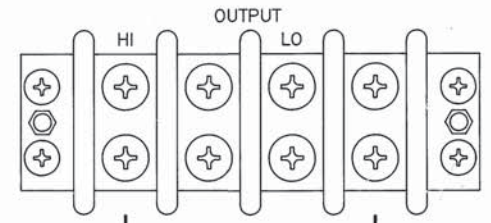

DETAIL A
SCALE: 1:1

CONTROLLED DOCUMENT

UNLESS OTHERWISE SPECIFIED DIMENSIONS ARE IN INCHES TOLERANCES: FRACTIONS ± 3 PLACE DECIMALS ± 2 PLACE DECIMALS ± .06 ANGLES ±		CONTRACT		BEHLMAN An Astrosystems Company	
DO NOT SCALE THIS DRAWING		DRAWN DATE D. MORTENSEN 93-7-28			
MATERIAL:		CHECKED RA 93-7-28		OUTLINE BL12 000	
NEXT ASSY USED ON		ENGR RA 93-7-28			
APPLICATION		SIZE	CODE IDENT NO.	REV	
		D	53636	106-909-510	
		SCALE	1/3	SHEET	

106-909-510

REVISIONS				
ZONE	LTR	DESCRIPTION	DATE	APPROVED
A		ADDED DETAIL A.		
B		ADDED CAP BD ASSY PER ECO 96-019.	96-05-30	RKL
C		REVISED PER ECO 98-081.	99-01-13	RKL
D		REVISED PER ECO 12-095	5-22-12	RKL
E		REVISED PER ECO 14-140 (SC)	10-06-14	<i>[Signature]</i>

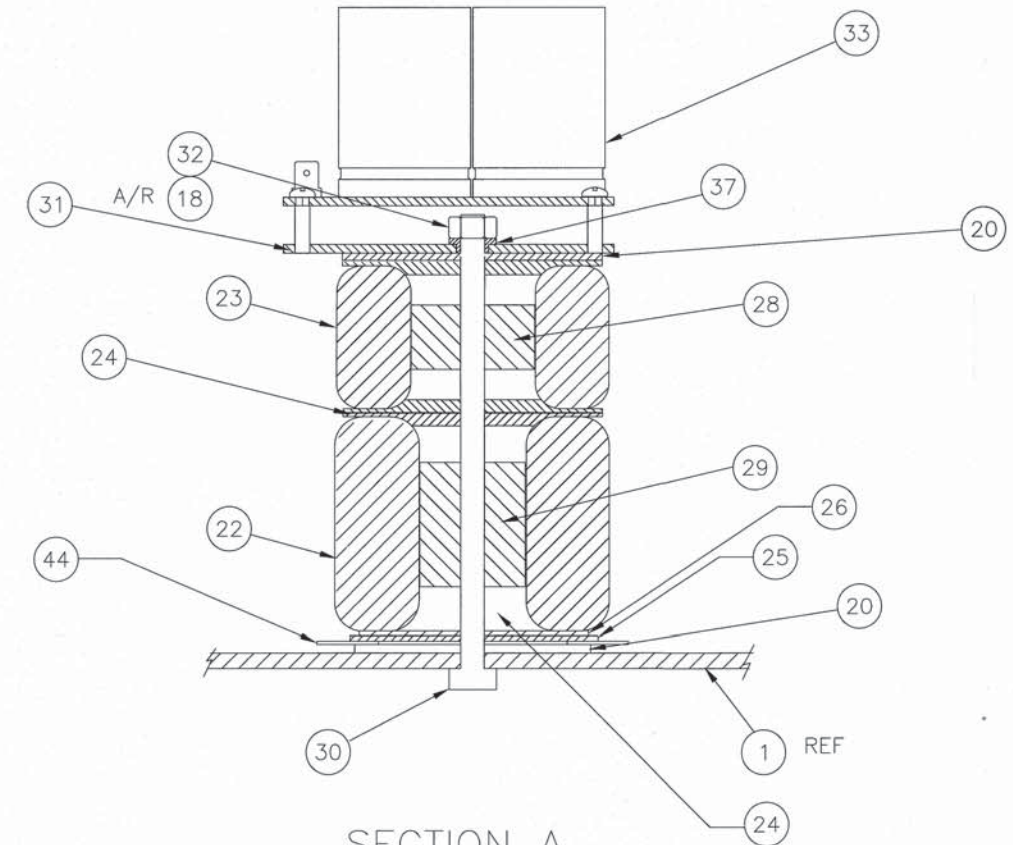
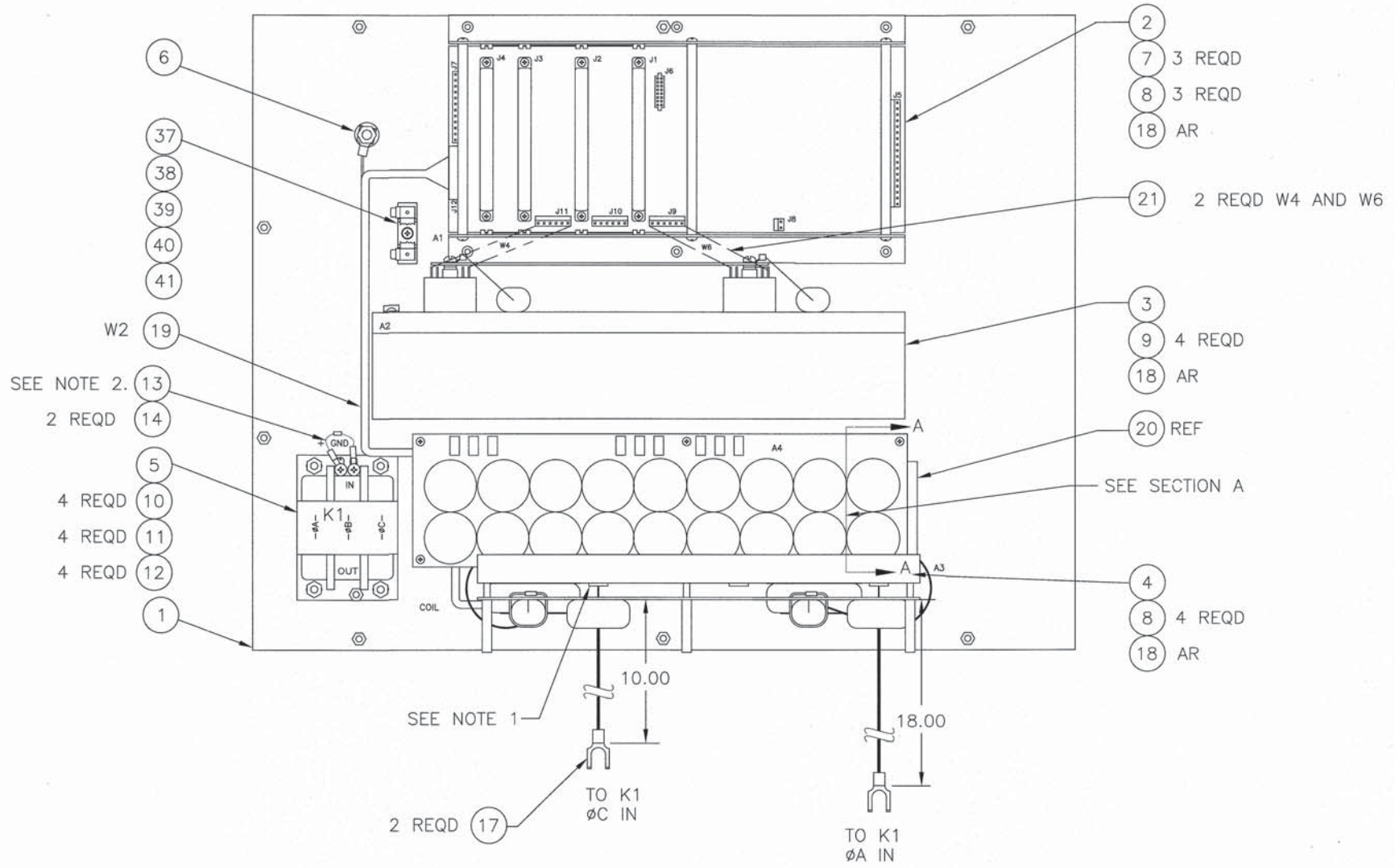

SECTION A
SCALE:NONE

CONTROLLED DOCUMENT

NOTE:
 1. ITEM 17 (LUG), MUST BE INSTALLED AFTER WIRE PASSES THROUGH GROMMETS (2 PLACES).
 2. CONNECT ITEM 13 (DIODE CR1) AS FOLLOWS:
 K1 COIL + TO CR1 CATHODE
 K1 COIL GND TO CR1 ANODE
 SEE SEPARATE PARTS LIST

CONN NO.	FROM	LUG ITEM NO.	TO	LUG ITEM NO.	AWG	COLOR	FUNCTION
10	A3L6-OUT	—	(TAG) K1ØA	17	10	WHT	
9	A3L4-OUT	—	(TAG) K1ØC	17	10	WHT	
8	A3L6-OUT	—	A3A1-E13	16	16	WHT	
7	A3L4-OUT	—	A3A1-E9	16	16	WHT	
6	A3L3-OUT	—	A3A1-E12	16	16	WHT	
5	A3L1-OUT	—	A3A1-E8	16	16	WHT	
4	A3L3-OUT	—	A3L6-IN	—	10	WHT	
3	A3L1-OUT	—	A3L4-IN	—	10	WHT	
2	A3L1-IN	—	A2Q5/6-C2E1	15	10	WHT	
1	A3L3-IN	—	A2Q1/2-C2E1	15	10	WHT	

WIRE RUN SCHEDULE

CONN NO.	FROM	LUG ITEM NO.	TO	LUG ITEM NO.	AWG	COLOR	REMARKS
20	A3A1-E5	—	NEUT STD	—	10	WHT	
19	CAP BD E9	16	GND STD	—	12	WHT	
18							
17	CAP BD E7	16	GND STD	—	12	WHT	
16	CAP BD E6	16	A2-E2 BUSS	15	12	ORN	LO -250
15							
14	CAP BD E4	16	A2-E2 BUSS	15	12	ORN	LO -250
13	CAP BD E3	16	A2-C1 BUSS	15	12	RED	HI +250
12							
11	CAP BD E1	16	A2-C1 BUSS	15	12	RED	HI +250

WIRE RUN SCHEDULE

UNLESS OTHERWISE SPECIFIED DIMENSIONS ARE IN INCHES		CONTRACT		BEHLMAN	
TOLERANCES: FRAC ± 3 PLACE DEC ± 2 PLACE DEC ± ANGLES ±		DRAWN J. ALGERIO DATE 92-06-03			
DO NOT SCALE THIS DWG		CHECKED <i>[Signature]</i> 12-1-14		BASE PLATE ASSY CONTROL CHASSIS BL4500 ,BL6000	
MATERIAL:		ENGR. <i>[Signature]</i> 12-1-14			
106-909-006	106-676-600	APPLICATION		SIZE CODE IDENT NO. D 53636	REV E
NEXT ASSY USED ON		SCALE 1/2" CAD FILE:106-906-006 E		SHEET 1 OF 1	

106-906-006

AutoCAD Generated Document

PROPRIETARY
 THE PROPRIETARY INFORMATION CONTAINED IN THIS DOCUMENT MUST NOT BE DISCLOSED TO OTHERS FOR ANY PURPOSE, NOR USED FOR MANUFACTURING PURPOSES WITHOUT PERMISSION OF BEHLMAN ELECTRONICS INC. THE ACCEPTANCE OF THIS DOCUMENT WILL BE CONSTRUED AS AN ACCEPTANCE OF THE FOREGOING CONDITION.
 BEHLMAN ELECTRONICS INC.
 HAUPPAUGE, NEW YORK

REVISIONS				
ZONE	LTR	DESCRIPTION	DATE	APPROVED
-	-	RELEASED FOR PRODUCTION	930216	D.M.
A	-	ADDED WIRE NUMBERS 24-29, CHANGED LUG AND OR WIRE COLOR ON WIRE #'S 18-22	93/11/8	D.M.
B	-	ADDED 2 CAP BOARDS	94-6-28	D.M.
C	-	ADDED ITEM NUMBERS 47 THRU 51.	95-7-27	D.M.
D	-	WIRE NO. 2(CR1+) WAS (CR4+)		D.M.
E	-	REVISED PER ECO 96-049	961018	D.M.
F	-	REVISED PER ECO 96-063	961113	D.M.
G	-	REVISED PER ECO 97-055	970812	P.R.
H	-	REVISED PER ECO 98-063	980723	P.R.
J	-	REVISED PER ECO 03-036	000514	P.R.
K	-	REVISED PER ECO 05-069	050601	RKL
L	-	REVISED PER ECO 06-101 (AGB)	060627	RKL
M	-	REVISED PER ECO 08-087 (AGB)	080728	RKL
N	-	REVISED PER ECO 12-052 (FPM)	04-16-12	RKL
P	-	REVISED PER ECO 14-193 (FPM)	12-1-14	
R	-	REVISED PER ECO 15-063	07-01-15	

NO.	CLR	AWG	TO	LUG	FROM	LUG	COMMENTS	
57	RED	20	T1-X13	-	A2J1-5	52,53		
56	BLK	20	T1-X14	-	A2J1-3	52,53		
55	RED	20	T1-X15	-	A2J1-4	52,53		
54	RED	20	FAN 3 +	-	A2J1-1	52,53	TAG FAN WIRES	
53	BLK	20	FAN 3 -	-	A2J1-2	52,53	2-COND CABLE	
52	RED	20	FAN 3 +	39	FAN 4 +	39	REF: DOOR FANS	
51	BLK	20	FAN 3 -	39	FAN 4 -	39	2-COND CABLE	
50	BLK	20	FAN 1 -	-	FAN 2 +	-	SEE NOTE 4	
49	BRN	10	K1-OUT(C)	37	T1-H3	36	SEE NOTE 6	
48	BRN	12	R6-B	-	K1 OUT (C)	37		
47	BRN	12	R5-A	-	K1 IN (C)	37		
46	BUSS	14	R5-B	-	R6-B	-	FOR INPUT MODELS C-1,-4	
45	BUSS	14	R5-A	-	R6-A	-	FOR INPUT MODELS C-1,-4	
44	BUSS	14	R5-B	-	R6-A	-		
43	BUSS	14	R3-B	-	R4-A	-	FOR INPUT MODELS C-2,	
42	BUSS	14	R1-B	-	R2-A	-	C-3,C-5,C-6,C-7	
41	BUSS	14	R3-B	-	R4-B	-	FOR INPUT MODELS C-1,-4	
40	BUSS	14	R3-A	-	R4-A	-	FOR INPUT MODELS C-1,-4	
39	BUSS	14	R1-B	-	R2-B	-	FOR INPUT MODELS C-1,-4	
38	BUSS	14	R1-A	-	R2-A	-	FOR INPUT MODELS C-1,-4	
37	RED	20	A1J1-5	-	T1-X13	35	SHARED LUG	
36	WHT	20	C1+	-	K1 COIL+	-		
35	WHT	20	C1-	-	K1 COIL-	-		
34	RED	10	K1 OUT (B)	37	T1-H2	36	SEE NOTE 6	
33	BLK	10	K1 OUT (A)	37	T1-H1	36	SEE NOTE 6	
32	RED	12	R4-B	-	K1 OUT (B)	37		
31	BLK	12	R2-B	-	K1 OUT (A)	37		
30	RED	12	R3-A	-	K1 IN (B)	37		
29	BLK	12	R1-A	-	K1 IN (A)	37	SEE DETAIL A	
28	-	-	-	-	-	-		
27	WHT	8	CR2 -	42	TB1 COMM	44		
26	BLK	10	CR3 -	37	CR4 +	37		
25	BLK	10	CR2 -	37	CR3 +	37		
24	BLK	10	CR1 -	37	CR2 +	37		
23	RED	20	A1J1-4	52,53	T1-X15	35	SHARED LUG	
22	BLK	20	A1J1-3	52,53	T1-X14	35	SHARED LUG	
21	BLK	20	A1J1-2	52,53	FAN 2 -	-	SEE NOTE 4	
20	RED	20	A1J1-1	52,53	FAN 1 +	-	SEE NOTE 4	
19	RED	6	TB1 + (HI)	45	CC HI	45	TO CONTROL CHASSIS-TAG	
18	BLK	6	TB1 - (LOW)	45	CC LOW	45	TO CONTROL CHASSIS-TAG	
17	WHT	6	TB1 COM	45	CC COM	45	TO CONTROL CHASSIS-TAG	
16	WHT	12	A2E4	38	TB1-COMM	-		
15	WHT	12	A1E4	38	TB1-COMM	-		
14	BLK	12	A2E6	38	TB1-(LOW)	-		
13	BLK	12	A1E6	38	TB1-(LOW)	-		
12	RED	12	A2E2	38	TB1+(HI)	-		
11	RED	12	A1E2	38	TB1+(HI)	-		
10	WHT	12	A2E3	38	TB1 COMM	-		
9	WHT	12	A1E3	38	TB1 COMM	45	COMM ONE SHARED LUG	
8	BLK	12	A2E5	38	TB1 - (LOW)	-		
7	BLK	12	A1E5	38	TB1 - (LOW)	45	LO ONE SHARED LUG	
6	RED	12	A2E1	38	TB1 + (HI)	-		
5	RED	12	A1E1	38	TB1 + (HI)	45	HI ONE SHARED LUG	
4	WHT	20	K1 COIL +	35	A2E8	35	SEE WIRE #36	
3	WHT	20	K1 COIL -	35	A2E7	35	SEE WIRE #35	
2	RED	8	CR1 +	42	TB1 + (HI)	44		
1	BLK	8	CR4 -	42	TB1 - (LOW)	44		
	NO.	CLR	AWG	TO	LUG	FROM	LUG	COMMENTS

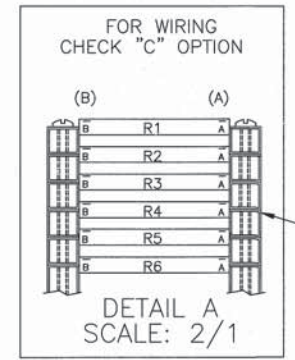
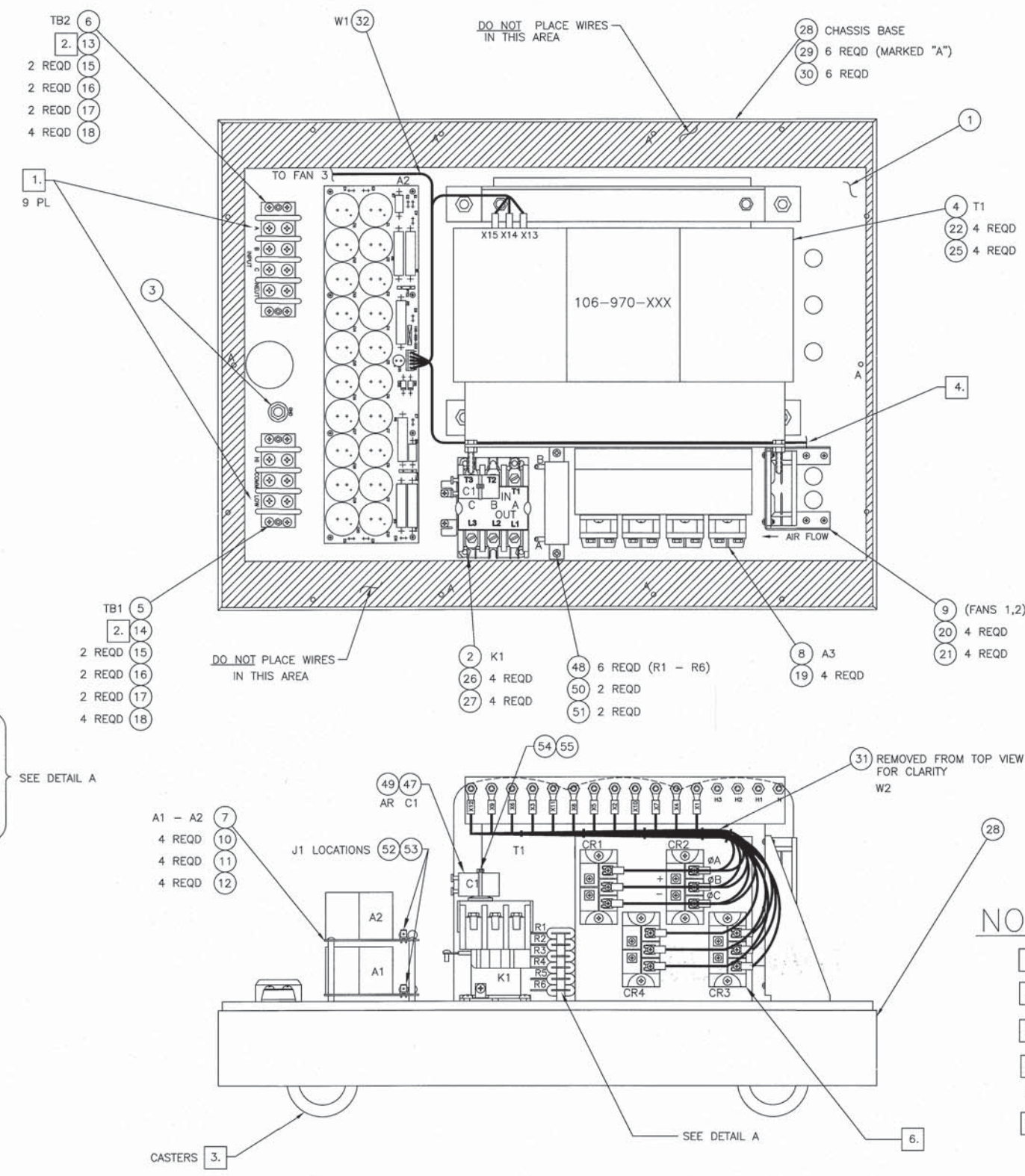

NOTES:

- MARK APPROX. WHERE SHOWN, .12 HIGH CHARACTERS, USING BLACK EPOXY INK.
- ITEMS 13 & 14 (SAFETY COVERS) REMOVED FOR CLARITY.
- INSTALL CASTERS (SUPPLIED WITH CABINET) BEFORE MOUNTING BASE PLATE.
- HOOK, SOLDER AND SLEEVE TO FAN.
- REFER TO DRAWING FOR SPECIFIC DASH NUMBER PRIOR TO USING THIS DRAWING.
- FOR MODELS C1 & C4, WIRES 33, 34, AND 49 ARE TO BE 8 AWG.

CONTROLLED DOCUMENT

SEE SEPARATE PARTS LIST

UNLESS OTHERWISE SPECIFIED DIMENSIONS ARE IN INCHES		THIS DRAWING SHALL ONLY BE CHANGED BY USE OF CAD		BEHLMAN BASE PLATE ASSY. BL20K	
TOLERANCES: FRAC 3 PLACE DEC ±.005 2 PLACE DEC ±.01 ANGLES ± 1°		DO NOT SCALE THIS DWG			
MATERIAL:		DRAWN: J.ALGERIO CHECKED: [Signature] ENGR: [Signature] QUALITY CONTROL: [Signature]	DATE: 930216 DATE: 7/23/16 DATE: 7/28/15	SIZE: D CODE IDENT NO.: 53636 SCALE: 1/3	REV: R SHEET: 1 OF 1

106-977-0XX	106-676-9XX
NEXT ASSY	USED ON
APPLICATION	

106-978-0XX

AutoCAD Generated Document

PROPRIETARY
 THE PROPRIETARY INFORMATION CONTAINED IN THIS DOCUMENT MUST NOT BE DISCLOSED TO OTHERS FOR ANY PURPOSE, NOR USED FOR MANUFACTURING PURPOSES WITHOUT PERMISSION OF BEHLMAN ELECTRONICS INC. THE ACCEPTANCE OF THIS DOCUMENT WILL BE CONSTRUED AS AN ACCEPTANCE OF THE FOREGOING CONDITION.
 BEHLMAN ELECTRONICS INC.
 HAUPPAUGE, NEW YORK

REV STATUS OF SHT		REVISIONS				DATE	APPROVED	DRL #	INIT
ZONE	LTR	DESCRIPTION	DATE	APPROVED	DRL #	INIT			
XX	A	FRONT PANEL ASSY WAS 107-185-000							
B	1	REV. PER ECD 01-114					010801	12719 Pm	

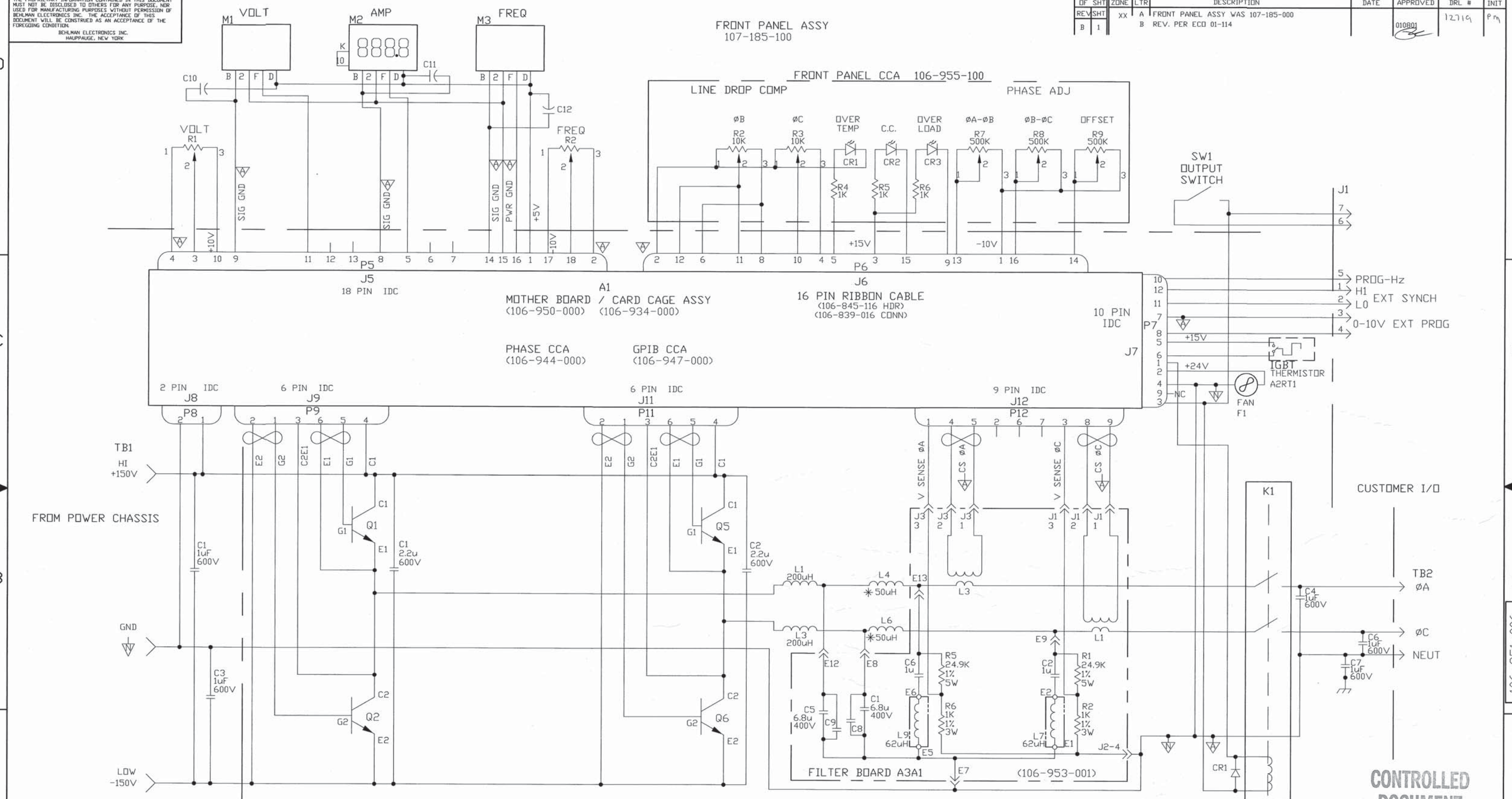

HEATSINK ASSY (106-907-006) A2

OUTPUT FILTER ASSY (106-908-006) A3

NOTE: * VALUE IS 100uH FOR ALL MODEL 6000'S.

106-909-006	106-676-6XX
NEXT ASSY	USED ON
APPLICATION	

UNLESS OTHERWISE SPECIFIED DIMENSIONS ARE IN INCHES
 TOLERANCES: FRAC
 3 PLACE DEC ±.005
 2 PLACE DEC ±.01
 ANGLES ± 1°
 DO NOT SCALE THIS DWG

THIS DRAWING SHALL ONLY BE CHANGED BY USE OF CAD

DRAWN	GLESKOWITZ	DATE	010724
CHECKED			
ENGR	S. B...		8/15/01
QUALITY CONTROL			
MANUFACTURING			

BEHLMAN

SCHEMATIC CONTROL CHASSIS BL6,000 AND BL12,000

SIZE	D	CODE IDENT NO.	53636	106-951-006	REV	B
SCALE	1:1	CAD FILE	951-006B.DWG	SHEET	1 OF 1	

CONTROLLED DOCUMENT

106-951-006