

**USER'S GUIDE AND
TECHNICAL REFERENCE**

**BEHLMAN MODEL
PF1351 SERIES AC POWER SUPPLY**

PART NO. 108-017-005

FOR SERVICE ASSISTANCE

CONTACT BEHLMAN
CUSTOMER SERVICE DEPARTMENT

PHONE TOLL FREE 1-800-874-6727

OR WRITE

BEHLMAN
CUSTOMER ELECTRONICS DEPARTMENT
80 CABOT COURT
HAUPPAUGE, NY 11788

PHONE: (631) 435-0410

FAX : (631) 951-4341

FOR SALES INFORMATION:

PHONE: (631) 435-0410

USA : (800) 874-6727

FAX : (631) 951-4341

LIMITED WARRANTY

Behlman Electronics, Inc. warrants, to the original purchaser, for a period of one (1) year from the date of shipment from Behlman, each item to be free from defects in material and workmanship. Behlman's obligation and the Purchaser's sole remedy for any breach or violation of this agreement is limited to adjustments, repair or replacement for parts which have been promptly reported by the Purchaser as having been, in its opinion, defective and so found by Behlman upon inspection. All replacement parts will become the property of Behlman on an exchange basis. This warranty will not apply if such adjustments, repair or parts replacement is required because of accident, neglect, misuse, failure of environmental controls, transportation damage or causes other than normal use.

If during the warranty period a defect should impair the performance of the unit, Behlman agrees, at its option, to repair or replace the unit or its defective components F.O.B. Behlman at 80 Cabot Court, Hauppauge New York 11788 or at another Behlman service facility at Behlman's option. To obtain service under this warranty, the original Purchaser shall notify Behlman at the above address or by Telephone at 631-435-0410 and provide information about the defect or impairment of performance. Behlman will then supply the Purchaser a Return Material Authorization (RMA) number. This number must be attached to the equipment sent back for warranty repair. Equipment must be shipped back to Behlman prepaid. No collect shipments will be accepted.

Behlman shall be excused from supplying warranty service if the equipment covers have been removed or if the unit has been subject to unauthorized repair. All service outside the scope of this Warranty shall be paid for by the Purchaser at Behlman's rates in effect at the time of repair. Behlman will not perform any repairs outside of the Warranty without written authorization by the Purchaser. If the repair is a warranty repair, Behlman will ship the unit back to the Purchaser, by a method determined solely by Behlman, prepaid. If the Purchaser requests any other means of transportation it shall be at the Purchaser's expense.

The use of the equipment shall be under the Purchaser's exclusive management and control. The Purchaser will be responsible for assuring the proper installation, use, management and supervision of the equipment. Behlman will not be liable for personal injury or property damage.

The foregoing warranties are in lieu of all other warranties, expressed or implied including without limitation warranties of merchantability and fitness for purpose.

In no event shall Behlman be liable for loss of profits, loss of use, or any other indirect, consequential or incidental damages. Purchaser agrees that Behlman will not be liable for any damages caused by the Purchaser's failure to fulfill any of the Purchaser's responsibilities set forth herein.

CLAIM FOR DAMAGE IN SHIPMENT

Under the FOB factory terms of sale, ownership and responsibility are transferred to the customer when the equipment leaves the factory. Each Behlman instrument is shipped from the factory in proper operating condition.

Immediately upon receiving equipment, unpack and inspect it for evidence of damage incurred in shipment. If equipment is damaged, file a claim with the freight carrier. Forward a copy of the damage claim report to Behlman. Include the model number, serial number and date the shipment was received. Behlman will advise the disposition of the equipment and will arrange for necessary repair or replacement.

RETURNING EQUIPMENT TO FACTORY

Do not return equipment to the factory without prior authorization from Behlman.

This equipment, like all precision electronic equipment, is susceptible to shipping damage. It contains heavy magnetic components as well as delicate electronics components. If equipment is returned without prior authorization, the shipment will be refused and the customer will be liable for all shipping, handling and repair costs. When packing for reshipment, use the original shock absorbent material and shipping container to prevent additional damage to the equipment.

Ensure that the return authorization numbers (RMA) is available on the container.

PACKING INSTRUCTIONS

RACK MOUNTED UNITS

- 1) Box(es) must be double wall with minimum 350 lbs. bursting test.
- 2) Box(es) must provide for a minimum of 2 to 3 inches of clearance around sides, top and bottom of unit.
- 3) When packing unit, utilize either a foam-in-place system or high density foam. Clearance provided for above must be completely filled with foam.

**FAILURE TO COMPLETELY SECURE UNIT IN BOX WILL ALLOW MOVEMENT
DURING SHIPPING, RESULTING IN DAMAGE.**

DO NOT USE PEANUTS OR BUBBLE WRAP

- 4) Secure box(es) to pallet(s). This is necessary to insure proper handling and protection during shipping.
- 5) Place the following warning label on box(es)

DO NOT STACK

- 6) Ship unit using a freight cargo carrier; air or ground.

SAFETY SUMMARY

The following safety precautions must be observed during all phases of operation, service, and maintenance of this equipment. Failure to comply with these precautions or with specific warnings elsewhere in the manual violates safety standards associated with the design and intended use of this equipment. This manual forms an integral part of the equipment and must be available to operating personnel.

GROUND THE EQUIPMENT

This equipment may have high leakage current to chassis due to EMI filtering requirements. To minimize shock hazard, the equipment chassis(s) must be connected to an electrical safety ground. This equipment is supplied with a three conductor line connection for single phase applications and/or a five wire connection for three phase applications. Both types include an earth terminal intended for safety ground connections. In addition, isolated installation sites may require neutral to earth connections as per NEC section 250 (National Electrical Code). Refer installation to licensed electrician or other qualified personnel.

DO NOT OPERATE IN EXPLOSIVE ATMOSPHERE

Do not operate the equipment in the presence of flammable gases or fumes. Operation of any electrical instrument in such an environment constitutes a definite safety hazard.

KEEP AWAY FROM LIVE CIRCUITS

Operating personnel must not remove equipment covers. Component replacement and internal adjustments must be made by qualified maintenance personnel. Do not replace components with power applied. Under certain conditions, dangerous voltage may exist even with the power removed. To avoid injuries, always disconnect power and discharge circuits before touching them. During normal operation the operator does not have access to internal hazardous voltages. However, depending on the user's application configuration, **HIGH VOLTAGES HAZARDOUS TO HUMAN SAFETY** may be normally generated at the output terminals. The customer/user must insure that the output power lines are labeled properly as to the safety hazard and that any inadvertent contact is eliminated.

DO NOT SERVICE OR ADJUST ALONE

Do not attempt internal service or adjustment unless another person, capable of rendering first aid and resuscitation is present.

DO NOT SUBSTITUTE PARTS OR MODIFY INSTRUMENT.

Because of the danger of introducing additional hazards, do not install substitute parts or perform any unauthorized modification to this equipment. Contact Behlman Electronics for proper replacement parts and specific service information.

DANGEROUS PROCEDURE WARNINGS



Warnings will precede potentially dangerous procedures in this manual. Instructions contained in the warning must be followed. Warnings will be preceded by the caution symbol (above).

RISK OF ELECTRIC SHOCK



This symbol warns personnel of hazardous conditions due to the exposure of hazardous voltage that can be lethal if contacted.

Neither Behlman Electronics, Hauppauge, NY, USA, nor any of the subsidiary sales organizations can accept any responsibility for personnel, material or inconsequential injury, loss or damage that may result from improper use of the equipment and/or accessories provided.

For additional safety related technical information, contact the Behlman Electronics sales department or local sales representative.

sales@behlman.com

or call in N.Y.

631-435-0410

TECHNICAL MANUAL PF1351 AC POWER SUPPLY

TABLE OF CONTENTS

<u>Section</u>	<u>Title</u>
1.0	Introduction
1.1	Specifications
1.2	Unpacking & Inspection
2.0	Installation
2.1	Power Requirements
2.2	Wiring
3.0	Operation
3.1	Features and Indicators
3.2	Operational Considerations
4.0	Maintenance/ Trouble Shooting
4.1	Performance Verification
5.0	Mechanical Outline
Appendices	
A	Option "I" IEEE-488 (GPIB) programming info
B	Option "I/R" RS-232 programming info
C	Option "A" analog control option info

SECTION ONE INTRODUCTION

- 1.0 The Behlman PF series of AC power supplies are designed to provide regulated AC power at frequencies and /or voltages not available from local utilities. All models are completely solid state, PWM switching types that provide high efficiency and overall reliability. These devices require very little maintenance and will provide years of trouble free service when used within their ratings. The models in this series include an active power factor correction circuit to reduce input harmonics associated with the conversion process used. These models are housed in an all steel, EIA rack mountable enclosure.

The block diagram below illustrates the conversion process performed by this equipment. AC power is applied and converted to DC by an active power factor corrected boost converter. This DC is then used to provide raw power for a class D amplifier. The amplifier is driven from a reference signal at the desired output frequency. The resulting amplified signal is applied to a step-up transformer to provide both isolation and the desired output voltage. Short circuit protection and current limit are performed by the control electronics.

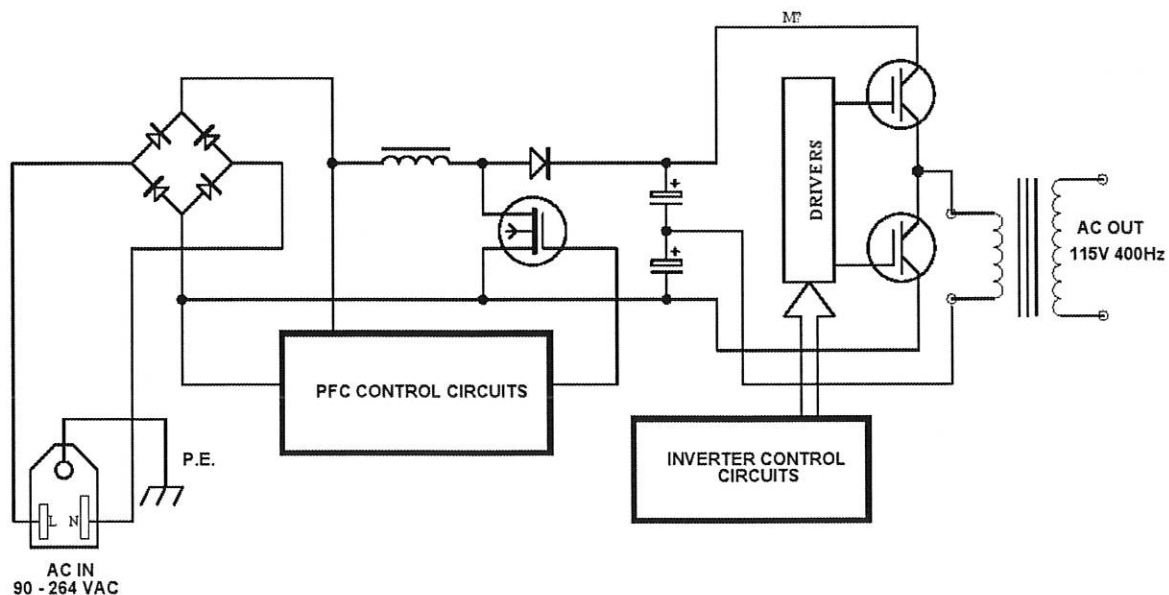

SIMPLIFIED BLOCK DIAGRAM BL1350PF

SECTION ONE

1.2 SPECIFICATIONS FOR AC POWER SUPPLY PF 1351 SERIES

INPUT POWER REQUIREMENTS:	95* to 270 VAC** 47 - 63 Hz @ 16A Max. (Full power from 108V – 267V) (*) input current limited to 16A.
AC OUTPUT POWER:	1200W (with 108 - 270VAC Input) 1350W @ 120V – 270V input @ 25C
OUTPUT FREQUENCY:	Variable from 45 – 500Hz
AC OUTPUT T.H.D.	1.5% TYPICAL @ 120V / 50Hz, resistive.
AC OUTPUT CURRENT:	10A @ 135V RANGE, 5A @ 270V RANGE.
AC REGULATION:	1 % No load to Full load, resistive.
AC REGULATION RESPONSE TIME	250 – 300 mSec, typical.
METERING:	
VOLTAGE:	+/- (0.5% of reading + 1% of range), 1V res.
CURRENT:	+/- (1% of reading + 1% of range), 0.1A res.
FREQUENCY:	+/- (1% of reading + (+/- 1Hz) 1Hz res.
PHYSICAL:	19" W x 17" D x 3.5" H EIA standard for 19" rack-mount cabinets (with RM kit).
WEIGHT:	39 lbs. (17.6 kgs)
OPERATING TEMPERATURE:	0 to +40 degrees Celsius.
STORAGE TEMPERATURE:	-10 to +60 Degrees Celsius.
SAFETY:	Evaluated to IEC-61010, general safety, Class1, pollution level 2. ** To conform, input voltage is limited to 250VAC. EMC-IEC61000
	OPTIONAL Remote interface conforms to IEC- 60950 where applicable.

SECTION ONE

1.3 UNPACKING AND INSPECTION

Remove the equipment from its packaging and inspect it for shipping damage. If the box shows signs of damage, retain it in case a claim needs to be filed with the shipping carrier. If the equipment shows signs of damage, **DO NOT** attempt to operate it. Contact Behlman immediately and file a damage claim with the shipper. Prior authorization is required before sending any equipment back to Behlman. This is in the form of a Returned Material Authorization number that must be obtained from Behlman. Any shipment sent without an RMA # will be refused and the customer will be liable for all shipping costs.

This equipment does not ship with any other accessories. A copy of the user/technical manual is provided in the shipping container. It is recommended that the serial number be verified and retained in case of any warranty claims. The warranty for this unit is one year for parts and labor. See the Warranty statement at the beginning of this document for specific information. All warranty repairs must be performed by Behlman or one of its authorized representatives. Contact sales@behlman.com for information regarding warranty repair or Reps.

SECTION TWO INSTALLATION AND WIRING

2.1 INSTALLATION

This device is designed primarily for desktop or bench top operation. This model may also be mounted in an EIA standard equipment rack using the RM adaptor kit available from Behlman. If the unit is to be rack mounted, it must be placed so as not to block the cooling vents on the sides, top, and rear panels. Rear support must also be provided. This may be in the form of internal support "rails" or chassis slides. Many equipment rack manufacturers can supply generic support brackets or shelves to be used with their racks. Racks that are completely sealed will require ventilation to remove heat generated by the AC power supplies exhaust.

The installation site must protect the power supply from moisture and any conductive particulate matter. **IN NO CASE** should this unit be operated in the presence of dripping or misting fluids. For continuous full power output, the ambient operating temperature should not exceed 40 degrees Celsius.

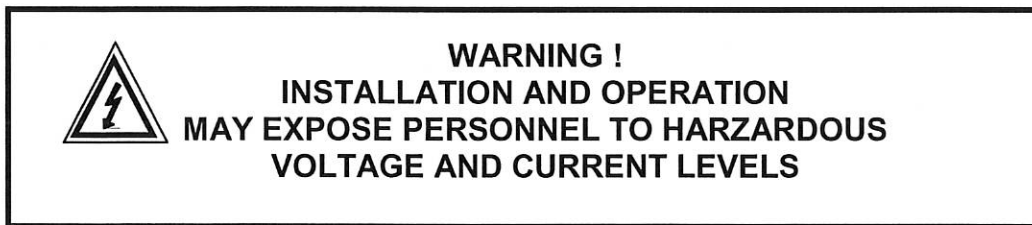

2.2 INPUT POWER CONNECTION

This unit operates from any AC voltage from 95 -270V with a frequency between 47 and 63 Hertz. A detachable line cord is provided that mates with the IEC-19 type receptacle (JI) on the rear panel. The other end of the supplied line cord is left un-terminated so that the end user can affix the proper plug to mate with power receptacles available at the installation site. Conformance to IEC safety standards limits the input to 250VAC.



WARNING

THIS DEVICE IS SUPPLIED WITH A 3 WIRE LINE CONNECTION THAT INCLUDES A PROTECTIVE EARTH CONDUCTOR (YEL/GREEN WIRE). THIS CONNECTION IS CRITICAL TO OPERATOR SAFETY AND MUST BE TIED TO THE INSTALLATION SITE PROTECTIVE EARTH. DUE TO COMPONENTS USED FOR EMI REDUCTION, THIS DEVICE MAY PRODUCE LEAKAGE CURRENTS THAT ARE HAZARDOUS. THE EARTH CONNECTION PROVIDES A RETURN PATH FOR THESE CURRENTS.

2.3 AC OUTPUT LOAD CONNECTIONS

Connect the load to either the front panel AC output safety sockets (4mm banana jacks) or the rear panel AC output at TB1. TB1 is marked "H" (AC high side), "L" (AC low side), and "G" (chassis). Note that this device produces output voltages that are hazardous under normal conditions. The end user must make sure that all output wiring is installed in a way that prevents inadvertent contact with operating personnel. **The use of warning labels is highly recommended.**

The output circuit of this device is transformer coupled and floating with respect to the input line. Either side of the AC output may be tied to earth or other potential. The maximum continuous floating voltage between either output terminal and ground must be limited to 500VDC. Refer to figure 2-1 for an illustration of typical output circuit configurations.

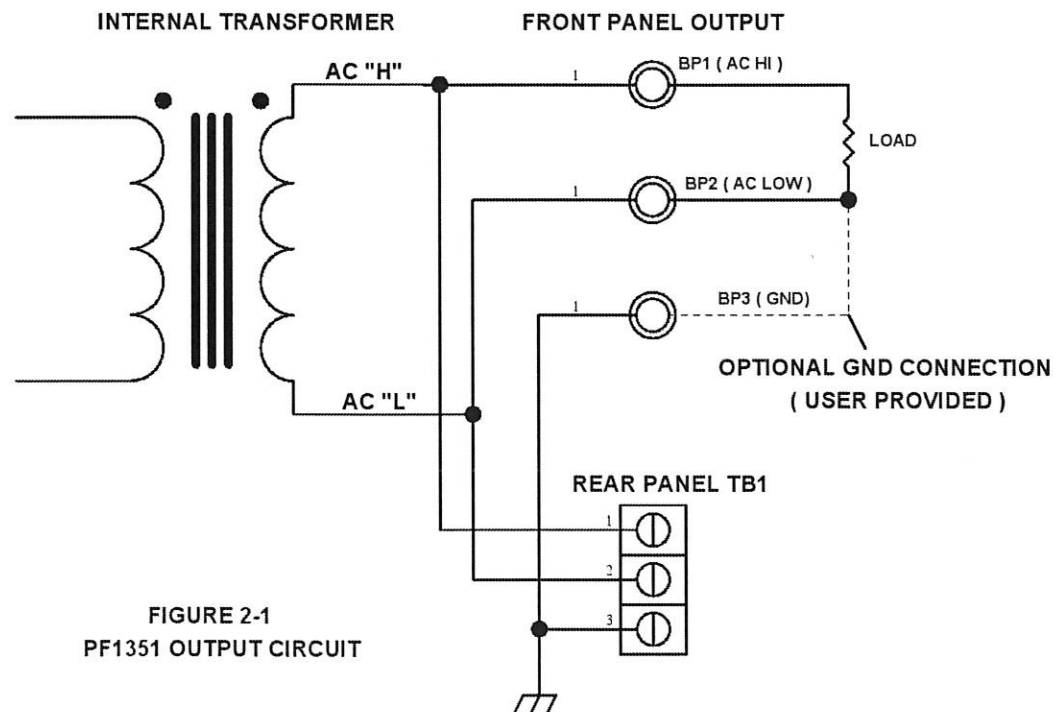

SECTION THREE OPERATION

3.1 CONTROLS AND INDICATORS

Table 3-1 below lists the controls, indicators, and other features associated with the model PF1351 AC power supply. Refer to figure 3-1 for locations.

ITEM	DESIGNATION	COMMENT/DESCRIPTION
1	AC Line switch	Power on/off switch.
2	LED indicators	Illuminates during output faults caused by either over temperature or over current or output short circuits (see text).
3	Digital Voltage Display	3 digit readout to display output volts.
4	Digital Current Display	3 digit readout, displays output current or frequency. Parameter to be displayed is selected by the SELECT switch (item 5).
5	Display SELECT Switch	Push button switch selects function of current /frequency display (4). When pushed LED will indicate which Parameter is selected.
6	VOLTS adjust	Multi-turn control sets output voltage.
7	FREQ adjust	Multi-turn control sets output frequency.
8	OUTPUT switch	Push in to turn output on. OUTPUT LED will illuminate when pushed.
9	RANGE switch	Push in to set unit to high range (0- 270V) RANGE LED illuminates when pushed.
10	Front Panel Output	Safety "sockets" in parallel with rear panel TB1. These mate with 4mm type safety "banana" jacks.
11	Rear Panel Output (TB1)	AC output terminals up to 10 AWG wire. In parallel with front panel output.
12	J1 AC Line input	IEC-20 receptacle.
13	F1 line Fuse	6.3 x 32 mm 16A /300V fuse. WARNING! Replace with same type and rating only.
14	Fan exhaust	Heated air exits via these openings.
15	Remote interface (optional)	May be one of three options. RS-232, IEEE 488 or Analog remote control. See manual text for additional information.

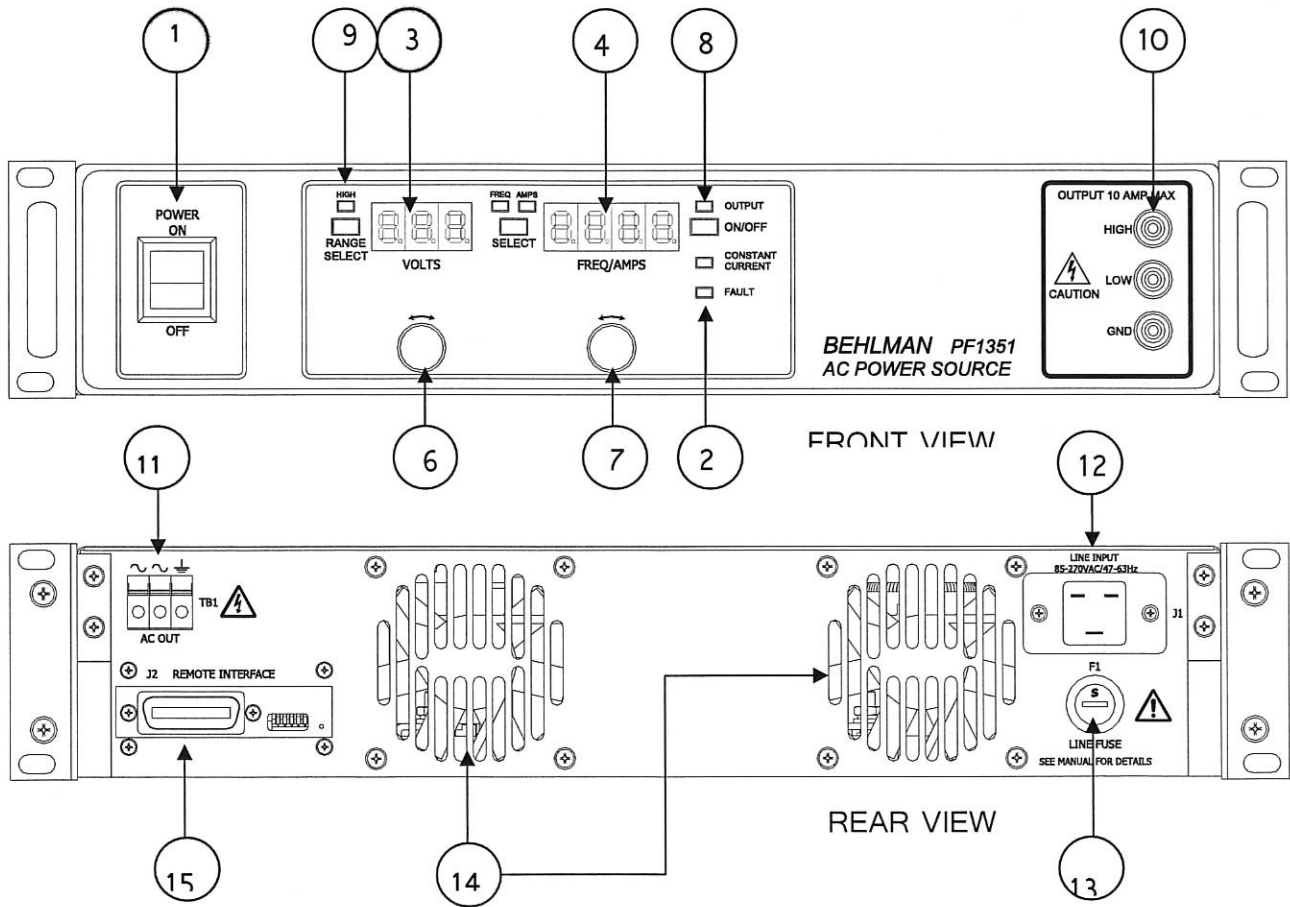

Figure 3-1 PF1351 Controls and Indicators

3.1 CONTROL AND INDICATORS (continued)

CONTROL OPTIONS

The PF 1351 series is available with any one of three remote control options. The table below summarizes these options.

OPTION TYPE	PHYSICAL INTERFACE	FEATURES
"I" GPIB	Rear panel IEEE-488 compliant connector	Isolated computer control of output voltage, frequency, range, and on/off relay. Read back of voltage, current, frequency and status
"IR" RS-232	Rear panel DB-9 female	Isolated computer control of output voltage, frequency, range, and on/off relay. Read back of voltage, current, frequency and status
"A" Analog remote control	Rear panel DB-9 female	Isolated 0-10VDC control of voltage and frequency. Digital control of output relay on/off and range via opto-coupled inputs. 5 - 18VDC range.

OTHER OPTIONS

- E** Extended frequency range of 45 to 1000Hz
- RM** Rackmount adapters (Set)
- L** Lock Pots, adds locking mechanism to front panel FREQ and VOLTS controls.
- MA** Mounting angles for rear support when rack mounting

MODIFIED STANDARD OR SPECIAL UNITS

Special units are sometimes provided based on specific customer needs. These may include internal or external differences from the standard model. These will be identified by a four digit suffix to the base model number. Manual addenda will be included as needed.

3.2 OPERATING INSTRUCTIONS

1. Connect the unit to a source of AC power between 90 & 267 VRMS and 47-63Hz.
NOTE: for full power operation, input must be at least 108V. Conformance with IEC safety standards limits the input to 250VAC and 16A. See section 2 of this manual for specific wiring information.
2. Set the PF1351 front panel controls as follows:

OUTPUT	=	Off (button out)
RANGE	=	As desired for load (Note: button in is high range)
SELECT	=	Frequency (button out)
VOLTS	=	Fully Counter Clockwise (CCW)
FREQ	=	Fully Counter Clockwise (CCW)

3. With loads connected and switched off (recommended), turn on the front panel switch and allow a few seconds for the power supply to stabilize. Use the VOLTS and FREQ adjust controls to set the desired output voltage and operating frequency. Make sure the FREQ LED is on, if not check the SELECT switch setting (button out).
4. Switch the PF1351 output on by pressing in the OUTPUT switch.
5. Switch on the loads. The output current may now be displayed by setting the SELECT switch to AMPS (button in position). The AMPS LED should be on.
6. To shut down, set the front panel power switch to off. **NOTE:** If the unit is turned off with no load attached, there will be period of approximately 90 seconds required before the unit can be switched back on. This is due to internal protection circuits and the long time constant of the internal capacitor banks.

It is also permissible to use the OUTPUT switch to turn the load on and off, however, certain loads can cause the internal relay contacts to wear prematurely. This is especially true for loads with capacitive or other high in-rush currents. When in doubt, use the procedure outlined above. This procedure will provide a transient free output.

It is also possible to have the output voltage set at zero, and then to turn on the OUTPUT switch. The voltage can then be increased to the required operating point by adjusting the VOLTS control clockwise. This method works best with linear loads and may be desirable for certain applications.

3.3 OPERATING CONSIDERATIONS

The output voltage and frequency may be varied at any time while the unit is loaded. It is recommended that the load be disconnected (off) while changing the range setting. This will prevent potentially damaging transients from reaching the load.

3.3 OPERATING CONSIDERATIONS (continued)

These AC power supply models are based on electronic circuits that utilize various power semi-conductors. As such, there is a limit to the amount of current that can be supplied.

Certain loads may draw short duration, very high peak currents that may activate protection circuits within the AC power supply. The Model PF1351 incorporates two distinctive over current circuits. The first responds to massive overloads like short circuits. This circuit can respond in a few tens of microseconds. Once activated, the AC output of the power supply is disabled and the front panel overload LED is lighted. To recover from this type of overload, the input power must be cycled off for about 30- 90 seconds.

The second current limit circuit responds to long term overloads. Once the current is increased beyond the output rating, the unit will enter a constant current mode. In this mode, the output voltage will reduce to limit the current if the load resistance is reduced further. The voltage will recover automatically once the overload is removed. The front panel Constant Current LED may light or flash under these conditions depending on the nature of the overload.

The internal temperature of the unit is monitored. If the temperature rises above a safe value, the outputs will be disabled and the front panel Over-Temp LED will turn on. Normal operation will resume once the unit has cooled to a safe level.

3.4 LIMITING LOAD IN RUSH CURRENTS

Loads that present high inrush currents may be started by limiting the current at start-up. This can be done externally with a simple series resistor and relay. The resistor is placed in series with the load for the estimated or measured inrush period. Once the inrush current has stabilized or tapered off, the relay is used to switch the resistor out of the circuit. NTC (Negative Temperature Coefficient) "thermistors" may be used. These devices start off with a nominal resistance value when cold (off). Once power is applied the current flow causes the temperature of the resistor to increase which in turn reduces the value of the resistance. The "hot" value may be several times lower than the cold value. These devices are available for currents exceeding 15 Amps.

3.5 OPERATION INTO LINEAR LOADS

The model P1351 will provide the best overall performance into a linear load. A linear load is characterized by that fact that its current wave shape is sinusoidal. The phase relationship between the voltage and current may be anything between zero and 90 degrees (leading or lagging). Some examples of linear loads are as follows: Most AC Motors, Power Transformers, Heating Elements, Resistors, Capacitors, Most Inductors, Incandescent Lighting (without dimmers), and most Solenoids.

OPERATIONAL CONSIDERATIONS (continued)

3.6 OPERATION INTO LINEAR LOADS

Operation into these types of loads usually cause little interaction with the AC power supply. The main concern with a linear load is the inrush current associated with it. Most heating elements and resistors have little or no inrush concerns and usually do not present any problem for the power source. Inductive and capacitive loads may present a special problem based on their construction and the way in which they are energized. Motors and tungsten filament lamps also present some special start-up concerns. The following is intended to give the end user some insight into applying the AC source to these types of loads.

3.7 DRIVING REACTIVE LOADS

Capacitors and inductors are reactive in nature. With large capacitors, if the voltage is applied during the peak of the AC cycle there may be a considerable inrush of current several magnitudes larger than the steady state current. This current is only limited by any series resistance that may be present in the load circuit. Under the right conditions, this could trip the overload protection circuits in the power source. Certain transformers and solenoids (inductance) can present a similar issue depending on their magnetic state when the voltage is applied.

Several methods can be used to prevent tripping the protection circuits in the power source. One common method is to insert a limiting impedance in series with the load. This could be a fixed resistor or NTC (negative temperature coefficient) thermistor. Also, zero crossing switching can be employed. The most obvious way to prevent a high inrush current is to apply the load with the voltage set to zero (or some low value) and energize the load slowly by turning up the voltage.

3.8 DRIVING LAMPS

Tungsten filament lamps, when cold, present a very low resistance. Once they are energized, their resistance quickly climbs to a steady state value. This characteristic must be accounted for when driving tungsten filament lamps. The same methods for driving reactive loads can be applied to tungsten.

3.9 DRIVING MOTORS

Driving an AC motor presents a special problem. Most motors require a starting current that is several times higher than the running current. This current may last for a few cycles to several seconds depending on the construction and mechanical load on the motor. This current is sometimes referred to as the motor's $I_{locked\ rotor}$ current. This current is not to be confused with the inrush current that usually occurs over the course of one or two cycles of the AC waveform. The model P1351's fold back current limiting can be an advantage when starting motors. During the starting period, the motor will attempt to draw excessive power from the power source. The fold-back circuit will reduce the output voltage in order to maintain the maximum current for the range in use.

3.10 OPERATION WITH REMOTE CONTROL OPTIONS

The PF1351 is available with several remote control options. These are:

1. RS-232 computer control (I/R option)
2. IEEE-488 computer control (I option)
3. Analog Remote Control option (0 -10VDC)

Each of the options allows control of the following:

1. Output Voltage Setting with 0.1V resolution
2. Output Frequency Setting with 1Hz resolution
3. Output on/off function via internal relay
4. Output Range function of 0-135VAC or 0-270VAC

In addition, the "I" and "I/R" options allow remote monitoring of output voltage, frequency and current. System status may also be "polled" to check for operational problems such as overloads or over temperature. The read back allows reporting of:

1. Output voltage with a resolution of 0.1V, accuracy is 2% of reading +/- 0.5V
2. Output Current with a resolution of 0.1A, accuracy is 2% of reading +/- 0.2A
3. Output Frequency with a resolution of 1Hz, accuracy is 1%, +/- 1 Hz

The specific programming information for each option will be included at the end of this document as an appendix. Note that only one option may be included. Check the rating label to see if options have been installed.

The following information applies to all three options:

When operating in remote mode, the front panel controls must be set as follows:

- | | | |
|------------------|---|--------------------------|
| 1. Volts | = | Fully counter –clockwise |
| 2. Frequency | = | Fully counter-clockwise |
| 3. Output Switch | = | Off (button out) |
| 4. Range | = | low (button out) |

If not done, the remote interface will not be able to properly control the unit as these control values will sum with the programmed value. Note that locking type controls (L option) are available to prevent in-advertent adjustment of the voltage and frequency controls. Consult with Behlman for further information. Full operating information for any included option will be provided at the rear of this manual.

**SECTION 4
MAINTENANCE AND TROUBLE SHOOTING**

4.1 MAINTENANCE

These power supplies are completely self contained solid state devices and do not require any routine maintenance. When used within their ratings they will provide many years of trouble free service. The only foreseen maintenance issue would be maintaining the ventilation “grills”. Any accumulation of dust and debris should be removed by light brushing and vacuuming.

4.2 TROUBLESHOOTING

**THESE UNITS DO NOT CONTAIN USER SERVICABLE PARTS
REFER ALL SERVICING TO QUALIFIED PERSONELL ONLY. DO NOT REMOVE COVERS
AND DISCONNECT POWER BEFORE REMOVING FOR SERVICE.**

Table 4-1 below should be consulted In the event a problem is encountered during the operation of this power supply.

OBSERVERED SYMPTOM	PROBABLE CAUSE	CORRECTIVE ACTION
No outputs, meter indicates 000	VOLTS control CCW	Adjust VOLTS control CW
Load does not operate, unit indicates proper output	OUTPUT switch is off, load not connected between HI and Lo AC output.	Check load is switched on. Check load is connected properly, See section 2 and 3.
AC output low or fluctuates, constant current LED is on or flashing.	Output overload.	Reduce load.
Output current not indicated.	Select switch set to “FREQ”	Check setting, refer to section 3-1
Output frequency not indicated	Select switch set to “AMPS”	Check setting, refer to section 3-1
AC output distorted.	Hi harmonic content to load current. Non-linear load applied	Check load current waveform.
AC output drops to zero when load is switched on. Overload LED is on.	Output overloaded or shorted by large in-rush current.	Check load requirement, see information in section 3 on starting difficult loads.
No outputs, no displays, input fuse blows repeatedly.	Internal fault.	Remove unit from use and refer to qualified service personnel. Contact factory for service.

WARNING! REPLACE FUSE WITH SAME TYPE AND RATNG ONLY.
6.3x32mm cartridge type, 16A / 300VAC minimum voltage rating.

4.3 PERFORMANCE VERIFICATION

The following procedure can be used to verify operation and calibration of the PF1351 AC power supply.



THE FOLLOWING PROCEDURE EXPOSES PERSONNEL TO HAZARDOUS VOLTAGE AND CURRENT LEVELS. REFER TO QUALIFIED PERSONS ONLY

4.3.1 EQUIPMENT REQUIRED

Table 4-1 lists the test equipment required to for performance verification. Other equipment may be substituted provided that it meets the minimum requirements set in the table.

#	DESCRIPTION	SUGGESTED TYPE	MINIMUM SPECIFICATIONS
1	AC WATTMETER	YOKAKAWA WT-230	AC volts, amps, & frequency 0.25% to 500Hz.
2	TEST LOAD BANKS	AVTRON	12 OHM +/- 5% @ 1.2KW 48 OHM +/-5% @ 1.2KW
3	OSCILLOSCOPE	TEK TDS 2000 SERIES	20 MHz Bandwidth.
4	VARIABLE AUTO-TRANSFORMER	SUPERIOR ELECTRIC MODEL 1020 or equal	0 TO 250V @ 2KW , 60Hz
5	DISTORTION METER	HP339A or equal	1.0% Full Scale to 500Hz Tuned rejection type.
6	TEST LEADS, PROBES	ANY / Fabricate	As required.

4.3.2 SETUP

Set up equipment as illustrated in figure 4-1. For the remainder of this procedure the AC power supply will be referred to as the DUT (Device Under Test). Turn on the power to test equipment and allow a 10 minute warm up period before commencing with the test.

4.3 PERFORMANCE VERIFICATION (continued)

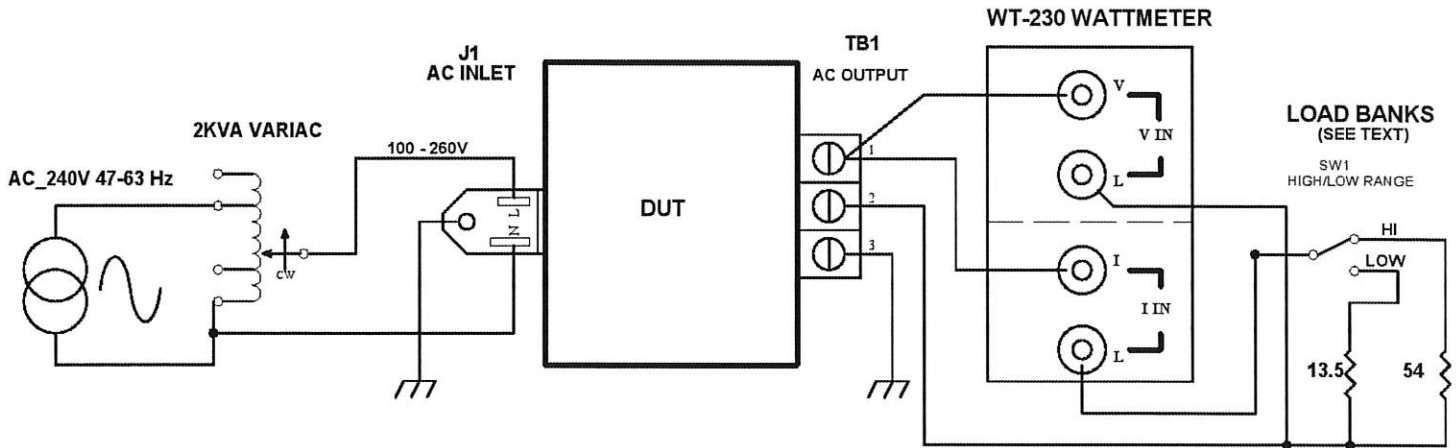

FIGURE 4-1 PERFORMANCE TEST SET UP

4.3.2 Set the PF1351 front panel controls as follows:

OUTPUT	=	Off (button out)
RANGE	=	Low (button out)
SELECT	=	Frequency (button out)
VOLTS	=	Fully Counter Clockwise (CCW)
FREQ	=	Fully Counter Clockwise (CCW)

4.3.3 Set the variac to provide 120V AC to the DUT. Switch the DUT on and confirm the displays are active and the cooling fans are on.

4.3.4 Set the DUT RANGE switch to the low range (button out) and adjust the DUT frequency control to provide a 100Hz output.

4.3.5 Adjust the DUT voltage to provide 100V output and set the output switch to on. Confirm an output of 100V @ 100Hz using the wattmeter.

4.3 PERFORMANCE VERIFICATION (continued)

4.3.6 With the load off, set the DUT voltage to the values listed in table 4-2. In each case record the actual output voltage vs. the displayed set value. These should agree within +/-0.5% of setting +/-1 digit.

TABLE 4-2

DISPLAYED SETTING	MEASURED OUTPUT VOLTAGE	LIMITS
25		23.88V - 26.12V
50		48.75V – 51.25V
75		73.7V – 76.37V
100		98.5V – 101.5V
135		133.3V – 136.7V

4.3.7 With the load off, set the DUT to the HIGH range. Set the DUT to the values listed in table 4-3. In each case, record the actual output voltage and confirm that it is with-in limits.

TABLE 4-3

DISPLAYED SETTING	MEASURED OUTPUT VOLTAGE	LIMITS
50		48.75V – 51.25V
100		98.5V – 101.5V
150		147.5V – 152.5V
200		198V – 202V
270		267.6V – 272.3V

4.3.8 With the load off, set the wattmeter to read frequency. Set the DUT to the frequencies listed in table 4-4. Confirm that the actual output frequency matches the display setting within the limits +/-1% of setting, +/- 1 digit.

TABLE 4-4

DISPLAY SETTING	MEASURED OUTPUT FREQUENCY	LIMITS
50 Hz		48.5Hz - 51.5Hz
100Hz		98 Hz – 102Hz
200Hz		197Hz – 203Hz
400Hz		395 Hz – 405Hz
500Hz		494 Hz – 506Hz

4.3 PERFORMANCE VERIFICATION (continued)

4.3.9 Set the DUT output voltage fully counter- clockwise (CCW) and readjust the output frequency to 100Hz. Connect the 12 ohm load (or closest value available) to the output of the DUT. Make sure the range is set to low (0-135V). Set the display select switch to AMPS (button in) on the DUT front panel. Using the DUT voltage control, adjust the output to provide the currents listed in table 4-5. In each case, confirm that the displayed current matches the current indicated on the wattmeter (+/- 1% of reading, +/- 1 digit).

TABLE 4-5

DISPLAYED SETTING	MEASURED OUTPUT AMPS	LIMITS
1.0A		.909A - 1.11A
2.0A		1.88A – 2.12A
5.0A		3.85A – 5.15A
7.5A		7.32A – 7.67A
10.0A		9.8A – 10.2A

4.3.10 CHECK OF LINE AND LOAD REGULATION

Set the DUT to 100V and 100Hz. The unit should be in the low range (0 -135v) and powering the 12 ohm load. While monitoring the output voltage on the wattmeter, adjust the AC line input with the variac from 108 to 250 VAC. Confirm that the DUT output voltage does not fluctuate more than 0.7volts from the initial set point.

Readjust the AC input to 120V. Set the load to 48 ohms and the DUT range to high, With the load off, set the output for exactly 200V as measured on the wattmeter. Connect the 48 ohm load and record the drop in voltage with load. This should be less than 2.0V. Note that the output voltage shall be measured as close to the output terminals as practical. The wattmeter voltage sense input should be tied to the rear panel of the DUT. Failure to do so may cause errors due to wiring voltage drops.

4.3.11 CHECK OF OUTPUT DISTORTION AND NOISE

Set the DUT as follows: RANGE =low, Frequency = 50Hz, output voltage 100V. Connect the 12 ohm load, distortion meter, and oscilloscope to the output of the DUT. Measure the distortion (THD) and confirm less than 1.5%.

Set the DUT output to zero using the VOLTS adjust and measure the residual noise level on the output using the oscilloscope. It should be less than 2.5V peak to peak.

For units with remote control options, see specific appendix at rear of this manual.

SECTION 5 MECHANICAL OUTLINE

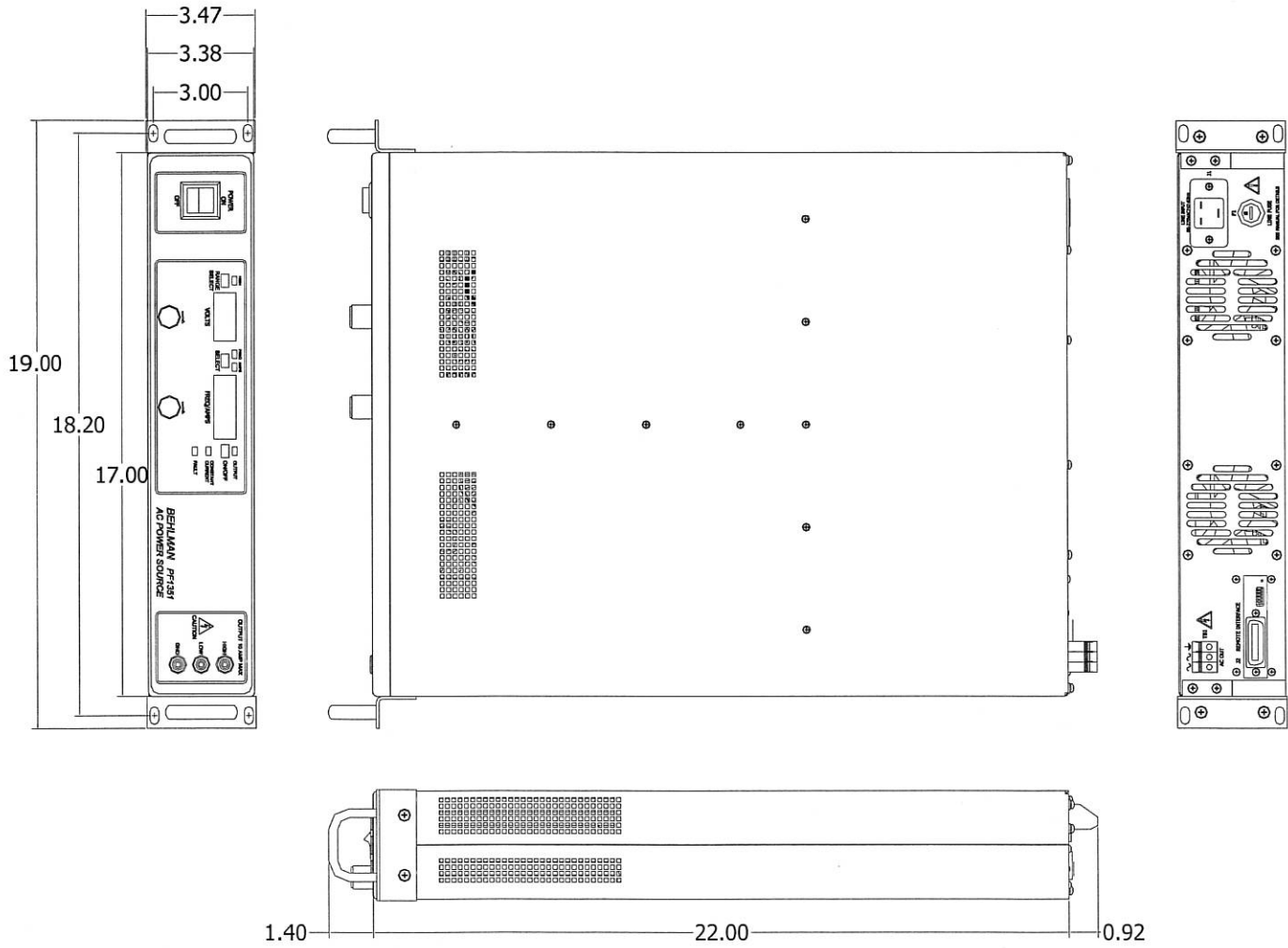

PF1351 MECHANICAL OUTLINE (All dimensions in inches).

REVISION HISTORY MNL108-017-005

REVISION HISTORY

REVISION	DATE	DESCRIPTION
-	11/2/2016	RELEASED AS MNL108-017-005